

# Makita

## Portable Cut-Off

355 mm (14'') MODEL 2414B

### INSTRUCTION MANUAL

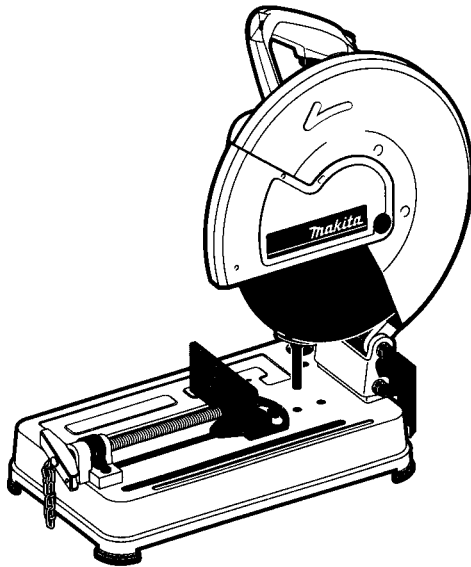

 **DOUBLE INSULATION**

#### SPECIFICATIONS

Wheel diameter	Hole diameter	No load speed (RPM)	Dimensions (L x W x H)	Net weight
355 mm (14'')	25.4 mm (1'')	3,800	500 mm x 280 mm x 615 mm (19-11/16'' x 11'' x 24-7/32'')	16.7 kg (36.8 lbs)

\* Manufacturer reserves the right to change specifications without notice.

\* Note: Specifications may differ from country to country.

**WARNING:** For your personal safety, READ and UNDERSTAND before using.

SAVE THESE INSTRUCTIONS FOR FUTURE REFERENCE.

# **IMPORTANT SAFETY INSTRUCTIONS**

## **(For All Tools)**

**WARNING: WHEN USING ELECTRIC TOOLS, BASIC SAFETY PRECAUTIONS SHOULD ALWAYS BE FOLLOWED TO REDUCE THE RISK OF FIRE, ELECTRIC SHOCK, AND PERSONAL INJURY, INCLUDING THE FOLLOWING:**

### **READ ALL INSTRUCTIONS.**

- 1. KNOW YOUR POWER TOOL.** Read the owner's manual carefully. Learn the tools applications and limitations, as well as the specific potential hazards peculiar to it.
- 2. KEEP GUARDS IN PLACE** and in working order.
- 3. REMOVE ADJUSTING KEYS AND WRENCHES.** Form habit of checking to see that keys and adjusting wrenches are removed from tool before turning it on.
- 4. KEEP WORK AREA CLEAN.** Cluttered areas and benches invite accidents.
- 5. DON'T USE IN DANGEROUS ENVIRONMENT.** Don't use power tools in damp or wet locations, or expose them to rain. Keep work area well lighted.
- 6. KEEP CHILDREN AWAY.** All visitors should be kept safe distance from work area.
- 7. MAKE WORKSHOP KID PROOF** with padlocks, master switches, or by removing starter keys.
- 8. DON'T FORCE TOOL.** It will do the job better and safer at the rate for which it was designed.
- 9. USE RIGHT TOOL.** Don't force tool or attachment to do a job for which it was not designed; For Example - Don't use circular saw for cutting tree limbs or logs.
- 10. WEAR PROPER APPAREL.** Wear no loose clothing, gloves, neckties, rings, bracelets, or other jewelry which may get caught in moving parts. Nonslip footwear is recommended. Wear protective hair covering to contain long hair.
- 11. ALWAYS USE SAFETY GLASSES.** Also use face or dust mask if cutting operation is dusty. Everyday eyeglasses only have impact resistant lenses, they are NOT safety glasses.
- 12. SECURE WORK.** Use clamps or a vise to hold work when practical. It's safer than using your hand and it frees both hands to operate tool.
- 13. DON'T OVERREACH.** Keep proper footing and balance at all times.
- 14. MAINTAIN TOOLS WITH CARE.** Keep tools sharp and clean for best and safest performance. Follow instructions for lubricating and changing accessories.

15. **DISCONNECT TOOLS** before servicing; when changing accessories such as blades, bits, cutters, and the like.
16. **REDUCE THE RISK OF UNINTENTIONAL STARTING.** Make sure switch is in off position before plugging in.
17. **USE RECOMMENDED ACCESSORIES.** Consult the owner's manual for recommended accessories. The use of improper accessories may cause risk of injury to persons.
18. **NEVER STAND ON TOOL.** Serious injury could occur if the tool is tipped or if the cutting tool is unintentionally contacted.
19. **CHECK DAMAGED PARTS.** Before further use of the tool, a guard or other part that is *damaged* should be carefully checked to determine that it will operate properly and perform its intended function — check for alignment of moving parts, binding of moving parts, breakage of parts, mounting, and any other conditions that may affect its operation. A guard or other part that is damaged should be properly repaired or replaced.
20. **DIRECTION OF FEED.** Feed work into a blade or cutter against the direction of rotation of the blade or cutter only.
21. **NEVER LEAVE TOOL RUNNING UNATTENDED. TURN POWER OFF.** Don't leave tool until it comes to a complete stop.
22. When servicing use only identical replacement parts.
23. **POLARIZED PLUGS.** To reduce the risk of electric shock, this equipment has a polarized plug (one blade is wider than the other). This plug will fit in a polarized outlet only one way. If the plug does not fit fully in the outlet, reverse the plug. If it still does not fit, contact a qualified electrician to install the proper outlet. Do not change the plug in any way.

**VOLTAGE WARNING:** Before connecting the tool to a power source (receptacle, outlet, etc.) be sure the voltage supplied is the same as that specified on the nameplate of the tool. A power source with voltage greater than that specified for the tool can result in **SERIOUS INJURY** to the user — as well as damage to the tool. If in doubt, **DO NOT PLUG IN THE TOOL.** Using a power source with voltage less than the nameplate rating is *harmful to the motor.*

**EXTENSION CORDS.** Make sure your extension cord is in good condition. When using an extension cord, be sure to use one heavy enough to carry the current your product will draw. An undersized cord will cause a drop in line voltage resulting in loss of power and overheating. Table 1 shows the correct size to use depending on cord length and nameplate ampere rating. If in doubt, use the next heavier gauge. The smaller the gauge number, the heavier the cord.

**TABLE 1 MINIMUM GAUGE FOR CORD SETS**

			Total Length of Cord in Feet			
			0 – 25	26 – 50	51 – 100	101 – 150
Ampere Rating More Than			A W G			
Not More Than						
0	–	6	18	16	16	14
6	–	10	18	16	14	12
10	–	12	16	16	14	12
12	–	16	14	12	Not Recommended	

## **ADDITIONAL SAFETY RULES**

1. Wear hearing protection during extended periods of operation.
2. Use only wheels having a maximum operating speed at least as high as “No Load RPM” marked on the tool’s nameplate. Use only fiberglass-reinforced cut-off wheels.
3. Check the wheel carefully for cracks or damage before operation. Replace cracked or damaged wheel immediately.
4. Secure the wheel carefully.
5. Use only flanges specified for this tool.
6. Be careful not to damage the spindle, flanges (especially the installing surface) or bolt, or the wheel itself might break.
7. Keep guards in place and in working order.
8. Hold the handle firmly.
9. Keep hands away from rotating parts.
10. Make sure the wheel is not contacting the workpiece before the switch is turned on.
11. Before using the tool on an actual workpiece, let it simply run for several minutes first. Watch for flutter or excessive vibration that might be caused by poor installation or a poorly balanced wheel.
12. Watch out for flying sparks when operating. They can cause injury or ignite combustible materials.
13. Remove material or debris from the area that might be ignited by sparks. Be sure that others are not in the path of the sparks. Keep a proper, charged fire extinguisher closely available.
14. Use the cutting edge of the wheel only. Never use side surface.
15. Do not attempt to keep the trigger in the ON position.
16. If the wheel stops during the operation, makes an odd noise or begins to vibrate, switch off the tool immediately.
17. Always switch off and wait for the wheel to come to a complete stop before removing, securing workpiece, working vise, changing work position, angle or the wheel itself.
18. Do not touch the workpiece immediately after operation; it is extremely hot and could burn your skin.
19. Store wheels in a dry location only.

**SAVE THESE INSTRUCTIONS.**

### Securing cut-off

The cut-off may be bolted (2 bolts) down to a level location using the bolt holes in the base.

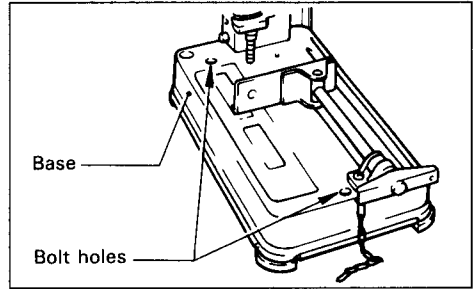

### Removing or installing cut-off wheel

#### CAUTION:

Always be sure that the tool is switched off and unplugged before removing or installing the wheel.

To remove the wheel, raise the safety guide. Press the shaft lock so that the wheel cannot revolve and use the socket wrench to loosen the hex bolt by turning it counterclockwise. Then remove the hex bolt, outer flange and wheel. (Note: Do not remove the inner flange, ring and O-ring.)

To install the wheel, follow the removal procedures in reverse.

#### CAUTION:

- Be sure to tighten the hex bolt securely. Insufficient tightening of the hex bolt may result in severe injury. Use the socket wrench provided to help assure proper tightening.
- Always use only the proper inner and outer flanges which are provided with this tool.
- Always lower the safety guide after replacing the wheel.

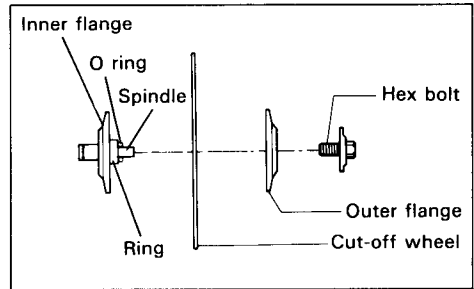
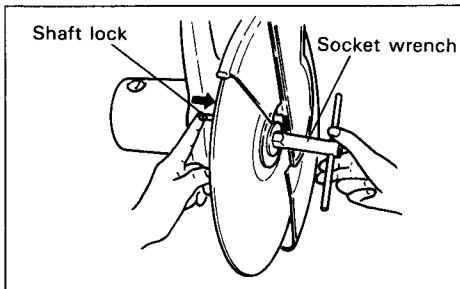

### Spark guard

The spark guard is factory-installed with its lower edge contacting the base. Before operation, loosen the screw and raise the spark guard so that its lower edge will be positioned approx. 60 mm (2-3/8") above the workbench or floor surface.

Otherwise sparks may fly around operation area.

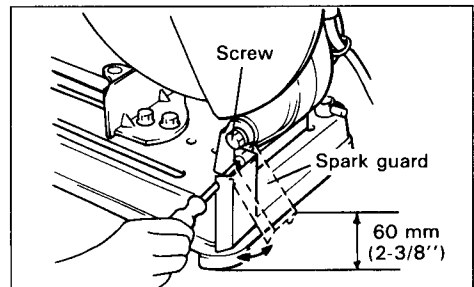

### Interval between vise and guide plate

The original spacing or interval between the vise and the guide plate is 0 - 170 mm (0 - 6-11/16"). If your work requires wider spacing or interval, proceed as follows to change the spacing or interval.

Remove the two hex bolts which secure the guide plate. Move the guide plate as shown in the figure and secure it using the hex bolts. The following interval settings are possible:

35 - 205 mm (1-3/8" - 8-1/16")

70 - 240 mm (2-3/4" - 9-7/16")

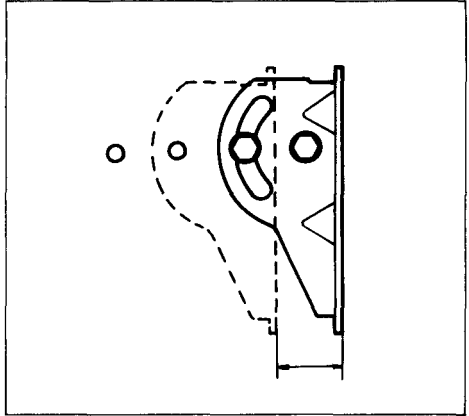
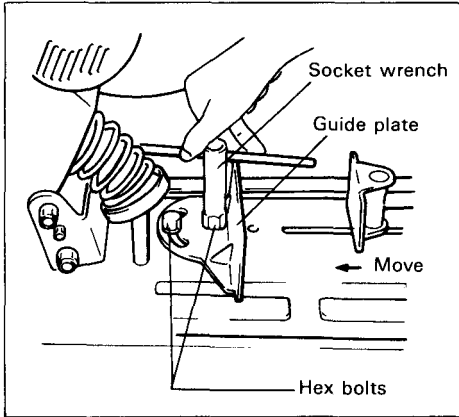

#### CAUTION:

Remember that narrow workpieces may not be secured safely when using the two, wider interval settings.

### Setting for desired cutting angle

To change the cutting angle, loosen the two hex bolts which secure the guide plate. Move the guide plate to the desired angle (0° - 45°) and tighten the hex bolts securely.

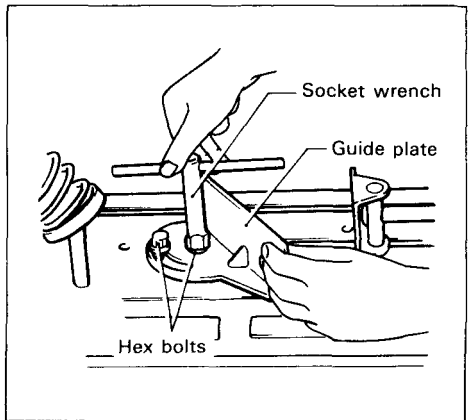

#### CAUTION:

Never perform miter cuts when the guide plate is set at the 35 - 205 mm (1-3/8" - 8-1/16") or 70 - 240 mm (2-3/4" - 9-7/16") position.

### Securing workpieces

By turning the vise handle counterclockwise and then flipping the vise nut to the left, the vise is released from the shaft threads and can be moved rapidly in and out. To grip workpieces, push the vise handle until the vise plate contacts the workpiece. Flip the vise nut to the right and then turn the vise handle clockwise to securely retain the workpiece.

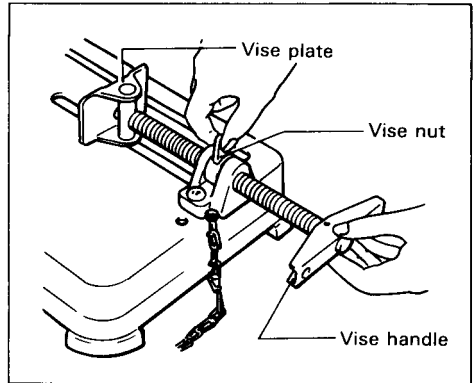

### CAUTION:

Always set the vise nut to the right fully when securing the workpiece. Failure to do so may result in insufficient securing of the workpiece. This could cause the workpiece to be ejected or cause a dangerous breakage of the wheel.

When the cut-off wheel has worn down considerably, use a spacer block of sturdy, non-flammable material behind the workpiece as shown in the figure. You can more efficiently utilize the worn wheel by using the mid point on the periphery of the wheel to cut the workpiece.

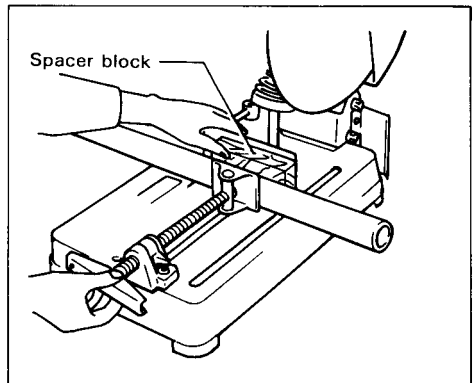

If you use a spacer block which is slightly narrower than the workpiece as shown in the figure, you can also utilize the wheel economically.

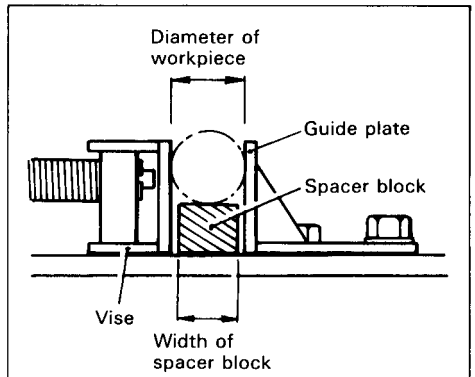



Long workpieces must be supported by blocks of non-flammable material on either side so that it will be level with the base top.

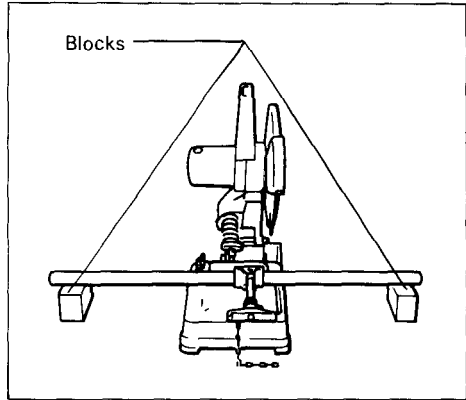

### Switch action

To prevent the trigger from being accidentally pulled, a lock-off button is provided as a safety feature.

To start the tool, press in the lock-off button and pull the trigger. Release the trigger to stop.

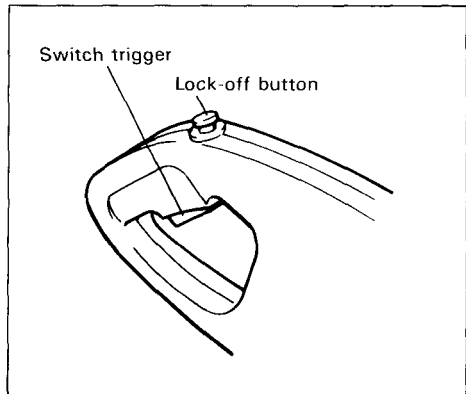

### CAUTION:

- Before plugging in the tool, always check to see that the switch trigger actuates properly and returns to the "OFF" position when released.
- When not using the tool, remove the lock-off button and store it in a secure place. This prevents unauthorized operation.

### Operation

Hold the handle firmly. Switch on the tool and wait until the wheel attains full speed before lowering gently into the cut. When the wheel contacts the workpiece, gradually bear down on the handle to perform the cut. When the cut is completed, switch off the tool and WAIT UNTIL THE WHEEL HAS COME TO A COMPLETE STOP before returning the handle to the fully elevated position.

### CAUTION:

Proper handle pressure during cutting and maximum cutting efficiency can be determined by the amount of sparks that is produced while cutting. Your pressure on the handle should be adjusted to produce the maximum amount of sparks. Do not force the cut by applying excessive pressure on the handle. Reduced cutting efficiency, premature wheel wear, as well as, possible damage to the tool, cut-off wheel or workpiece may result.

### Cutting capacity

Max. cutting capacity varies depending upon the cutting angle and workpiece shape.

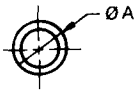
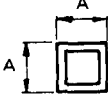
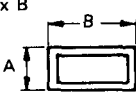
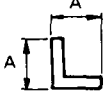
Cutting angle \ Workpiece shape				
90°	115 mm (4-1/2")	120 mm (4-23/32")	115 mm x 142 mm (4-1/2" x 5-5/8") 102 mm x 197 mm (4" x 7-3/4") 70 mm x 240 mm (2-3/4" x 9-7/16")	139 mm (5-1/2")
45°	115 mm (4-1/2")	106 mm (4-3/16")	115 mm x 102 mm (4-1/2" x 4")	100 mm (3-15/16")

### Tool hand slide system

The tool head slides back toward you approx. 17 mm(12/32") when you pull the handle. This system is convenient for the following applications.

1. When cutting thick pipes or bars:  
Move the handle back and forth to slide the tool head. This will help increase cutting efficiency and prevent wheel loading.
2. When cutting channels or angles:  
If a portion of the workpiece near you is left uncut, pull the handle. The tool head slides back and the wheel cuts the remaining uncut portion. If the uncut portion cannot be cut even by using this method, use a spacer block as explained above.

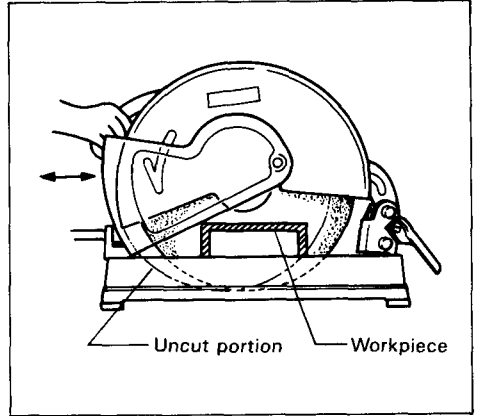
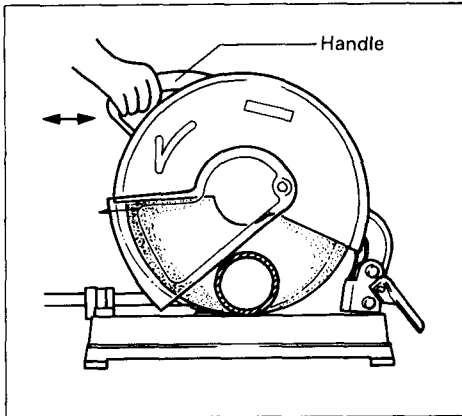

### Carrying the tool

Fold down the tool head to the position where you can attach the chain to the hook on the handle.

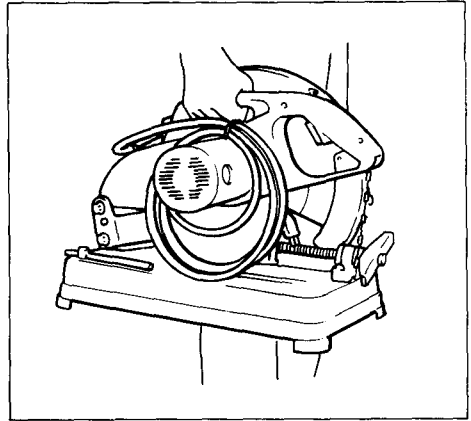

## MAINTENANCE

### CAUTION:

Always be sure that the tool is switched off and unplugged before attempting to perform inspection or maintenance.

### Replacing carbon brushes

Remove and check the carbon brushes regularly. Replace when they wear down to the limit mark. Keep the carbon brushes clean and free to slip in the holders. Both carbon brushes should be replaced at the same time. Use only identical carbon brushes.

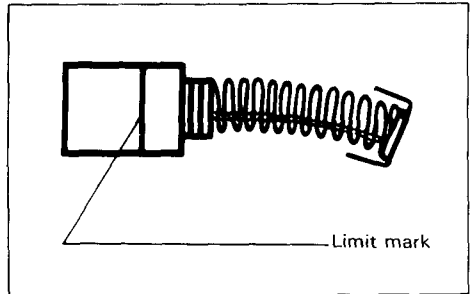

Use a screwdriver to remove the brush holder caps. Take out the worn carbon brushes, insert the new ones and secure the brush holder caps.

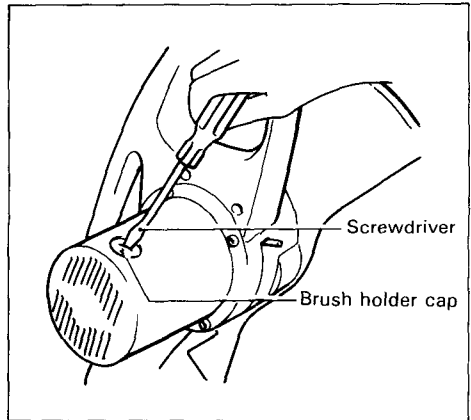

To maintain product SAFETY and RELIABILITY, repairs, any other maintenance or adjustment should be performed by Makita Authorized or Factory Service Centers, always using Makita replacement parts.

## OPTIONAL ACCESSORIES

The accessories listed in this manual are available at an extra cost from your Makita distributor or Makita factory service center. Service centers are listed on the warranty card packed with your tool.

### CAUTION:

These accessories or attachments are recommended for use with your Makita tool specified in this manual. The use of any other accessories or attachments might present a risk of injury to persons. The accessories or attachments should be used only in the proper and intended manner.

- **Abrasive cut-off wheel**  
(5 per pkg)

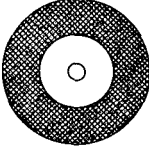

For all ferrous materials (Steel, cast iron) and other hard metals.

Part No.	Diameter (mm)	Hole diameter (mm)
724606-7	355 (14")	1" (25.4)
724603-3		

Reinforced with fiberglass.

- **Socket wrench 17**  
Part No. 782210-8

