

DEWALT®

DW743

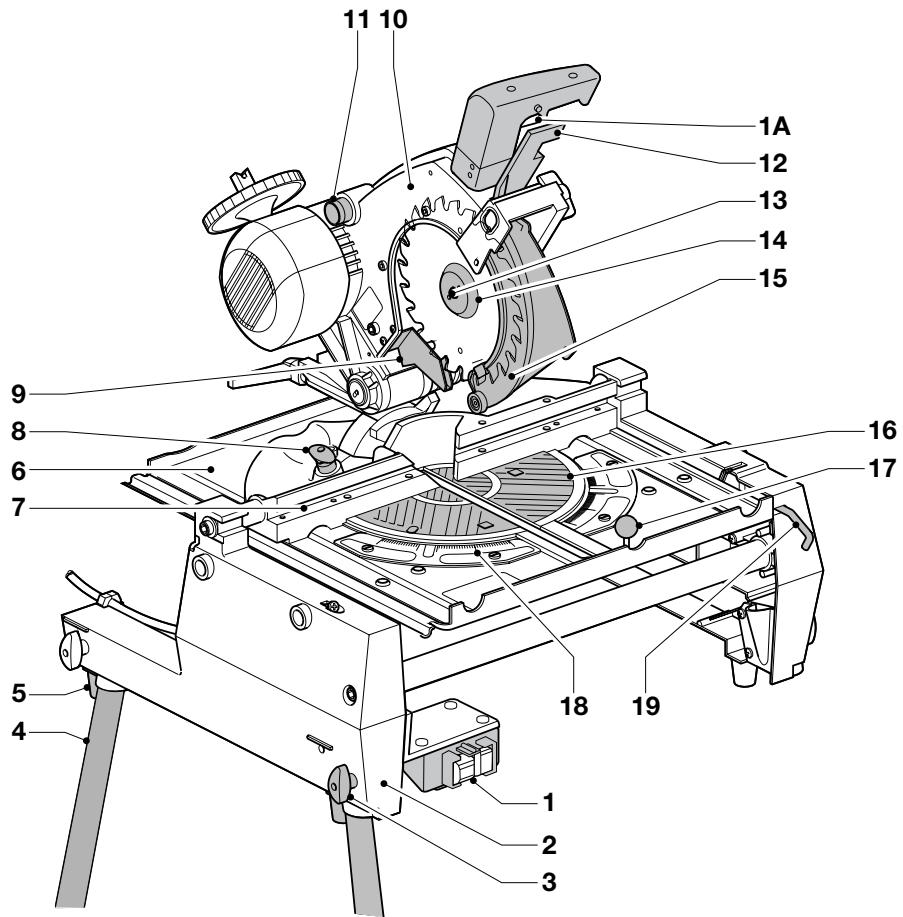

A1

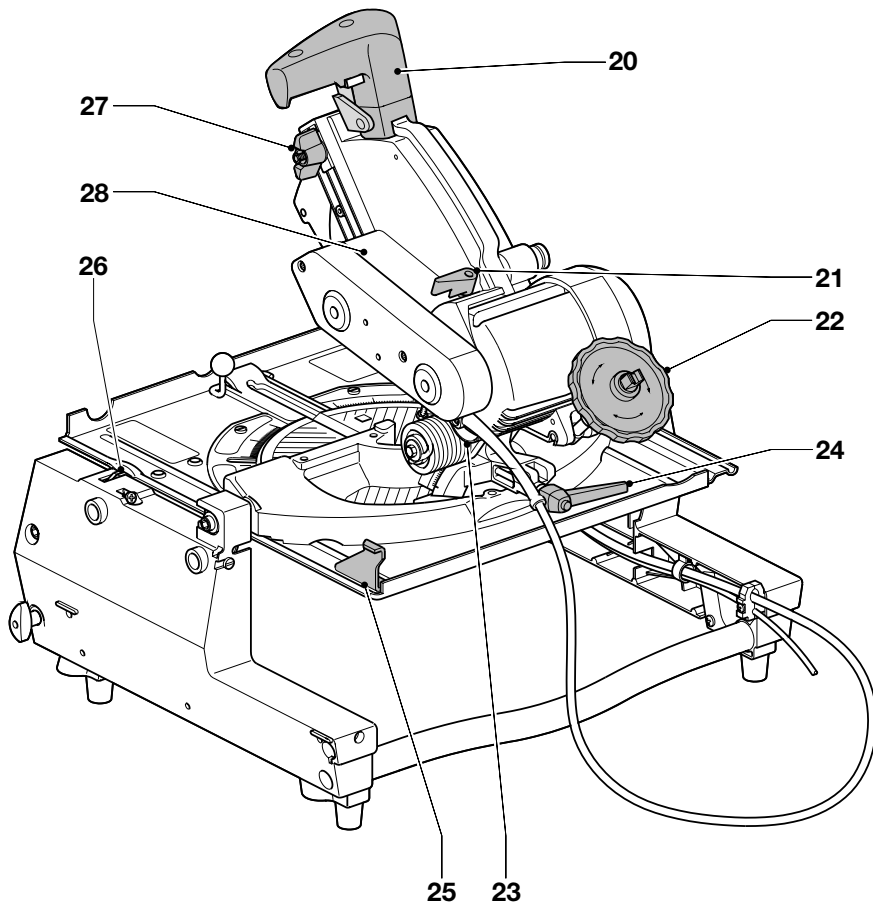

A2

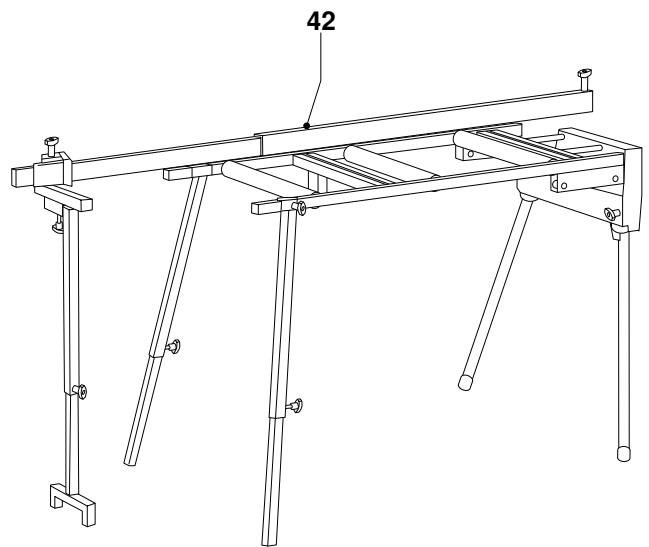
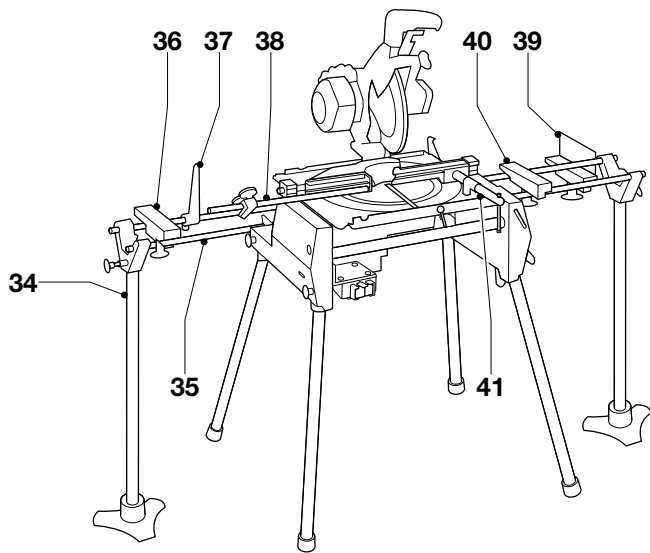
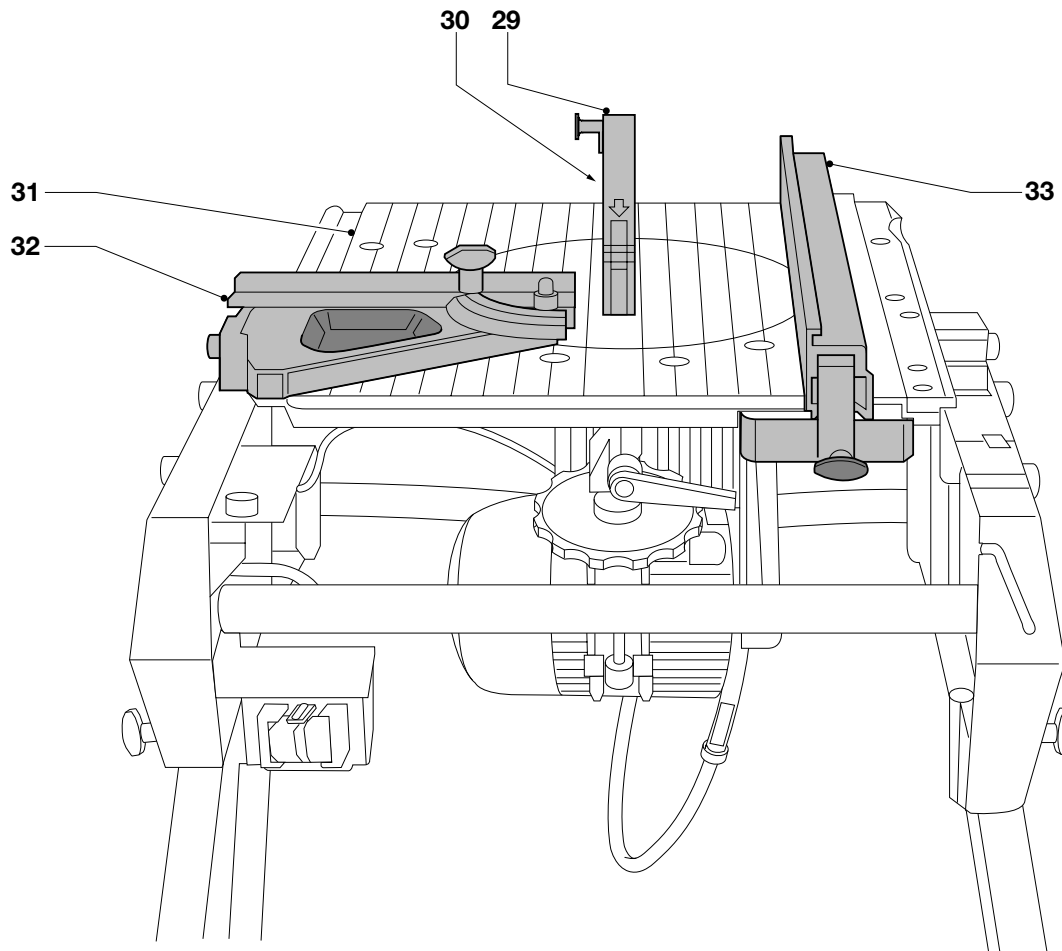

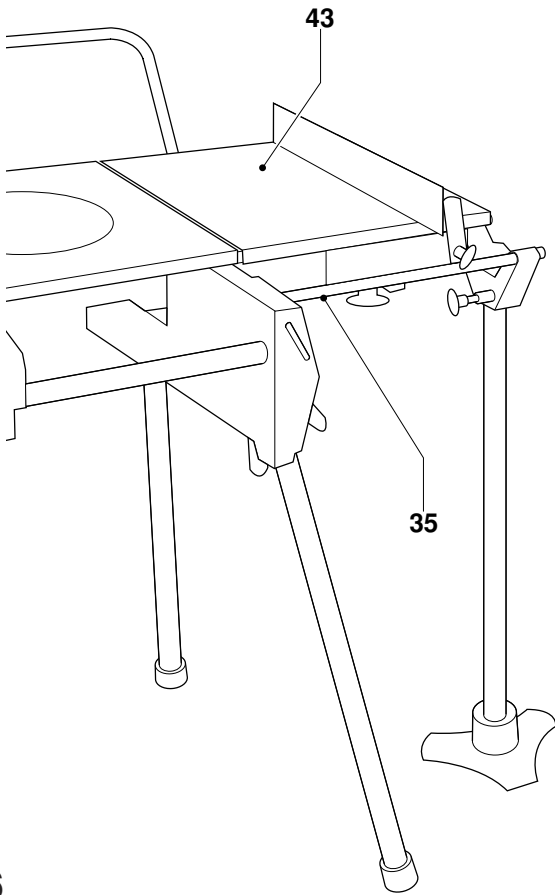

A6

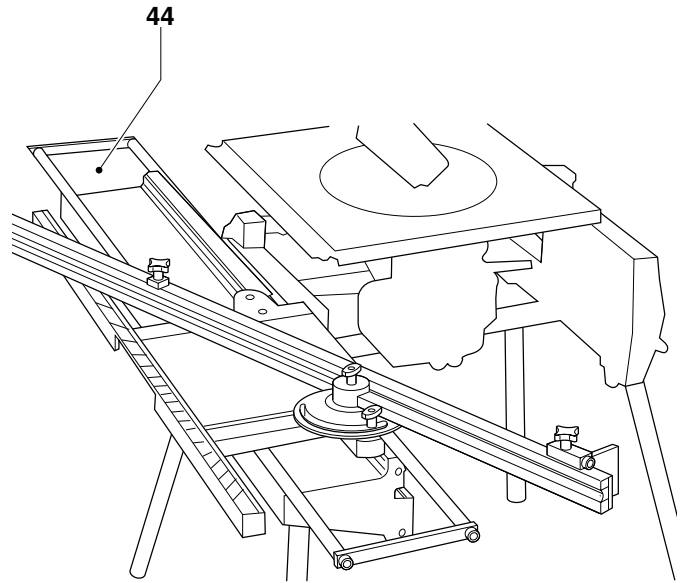

A7

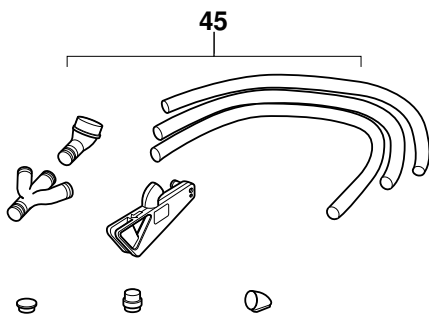

A8

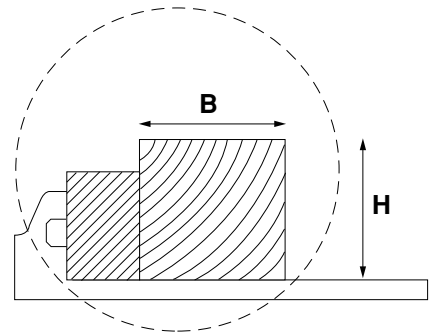

B1

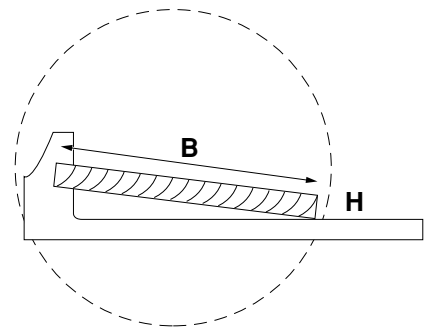

B2

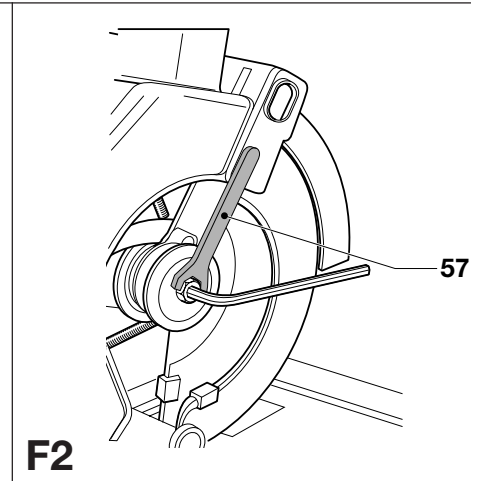
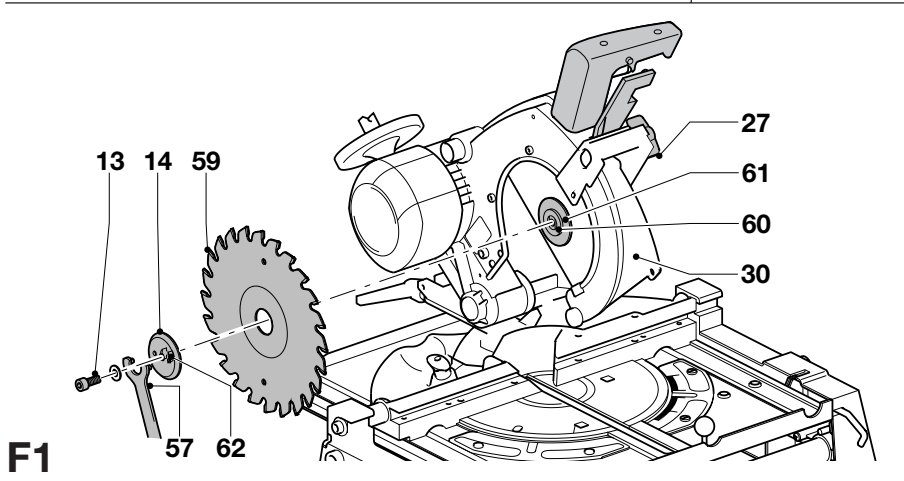
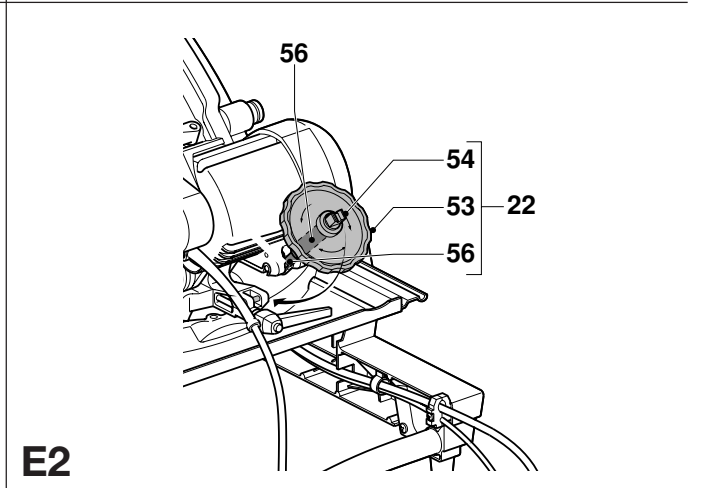
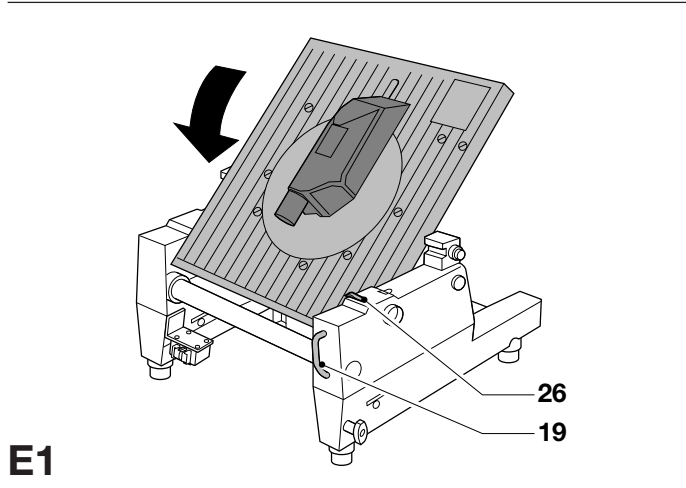
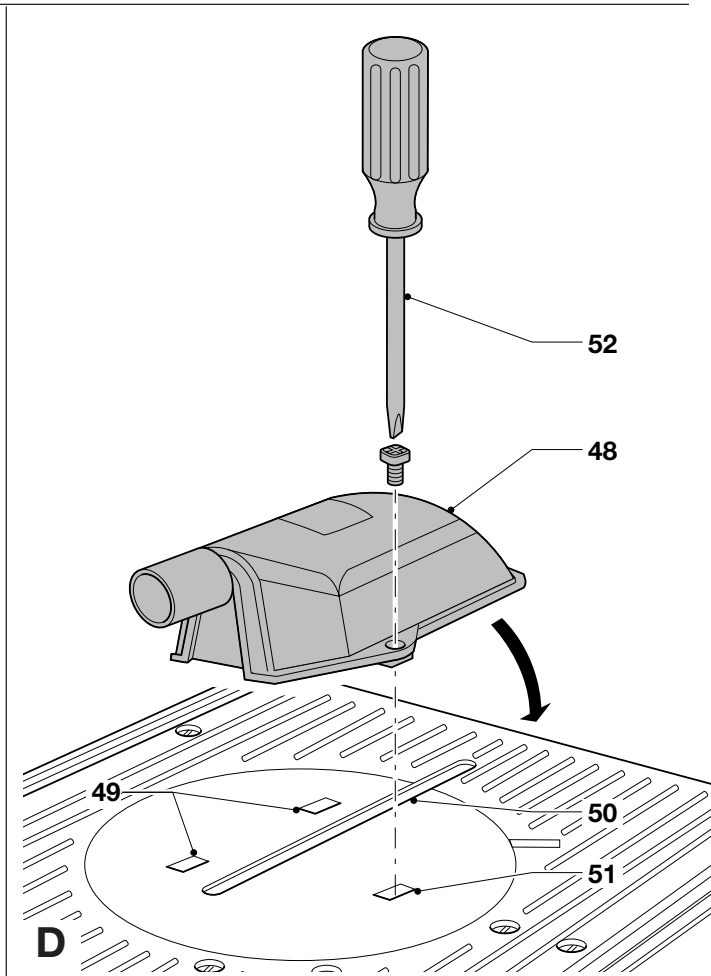
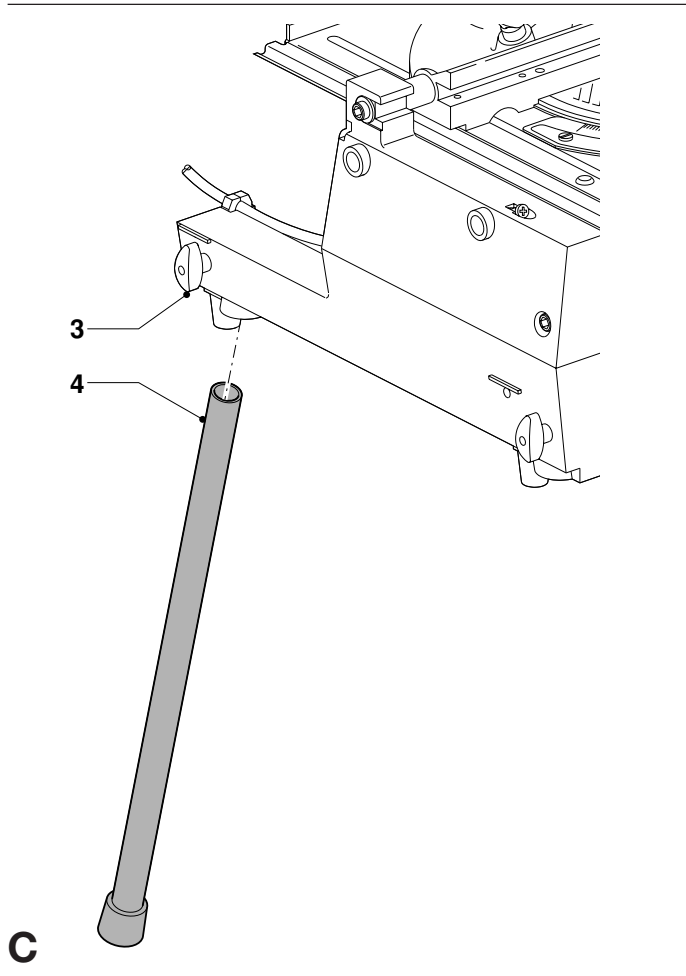

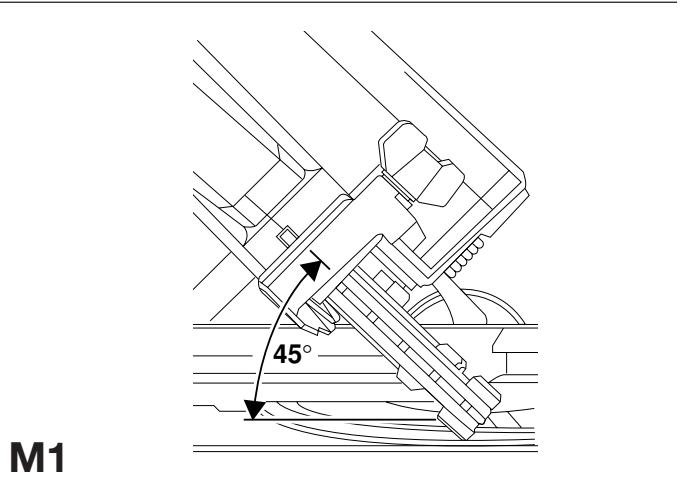
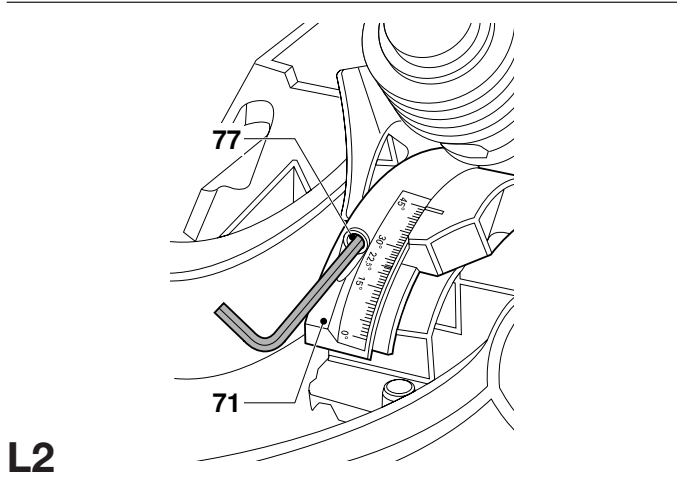
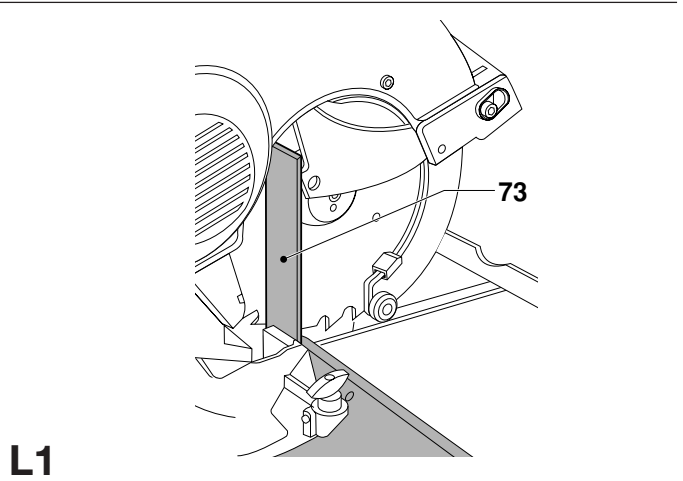
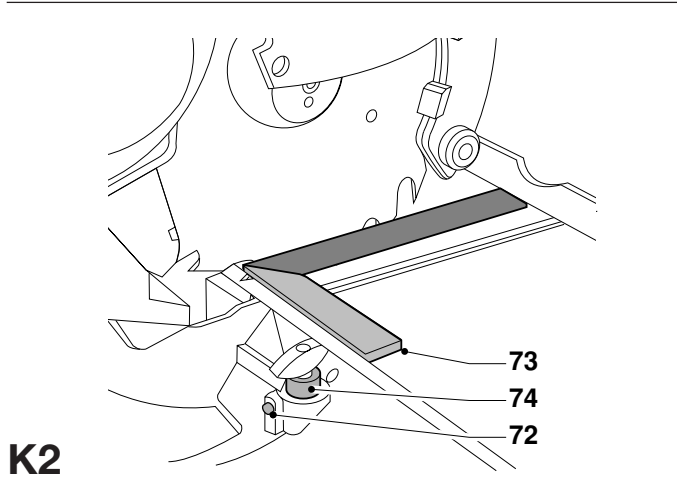
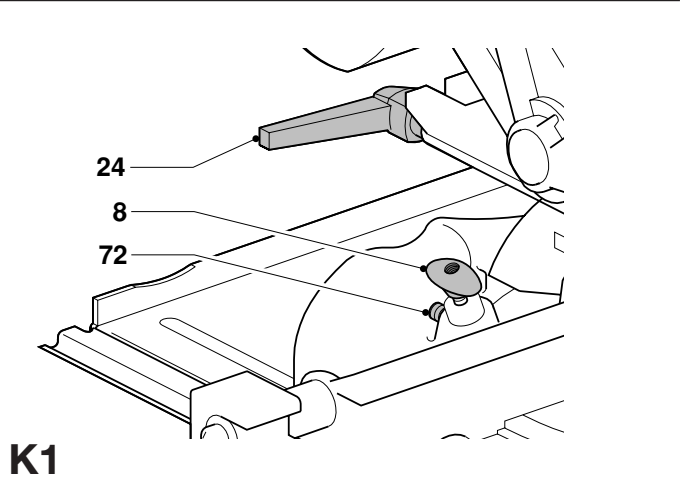
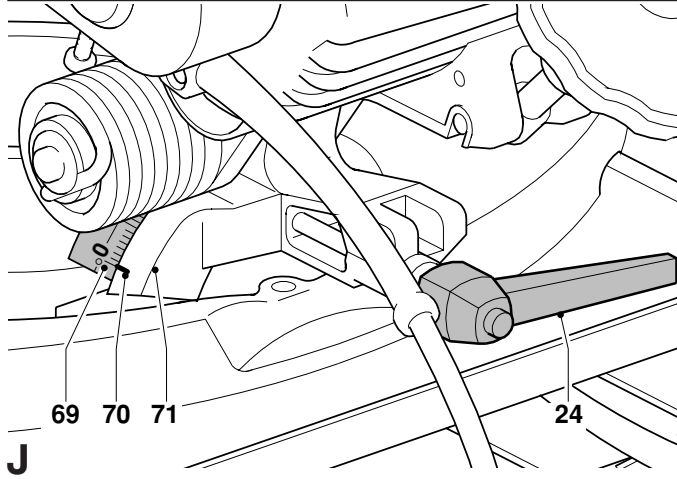
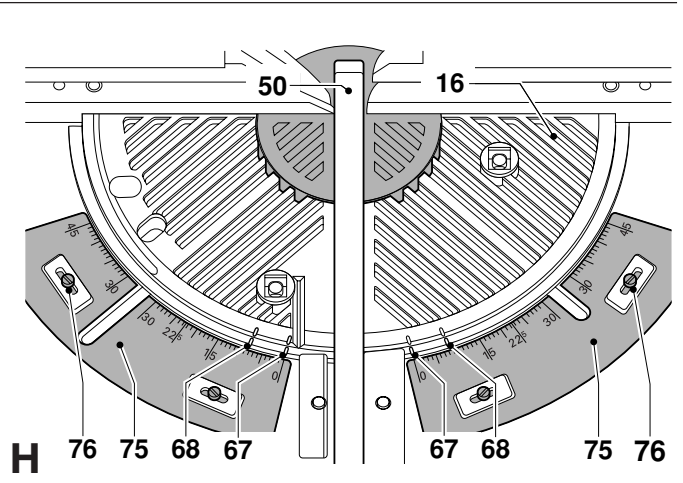
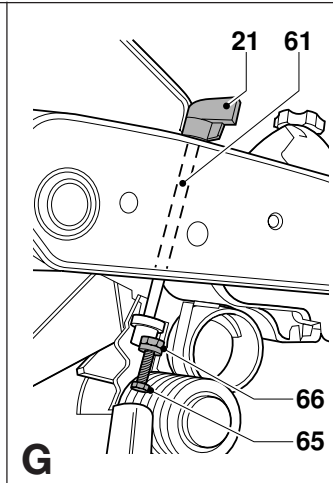
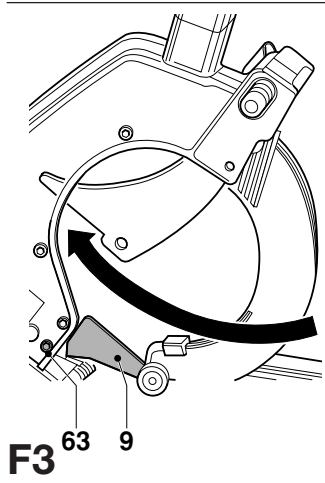

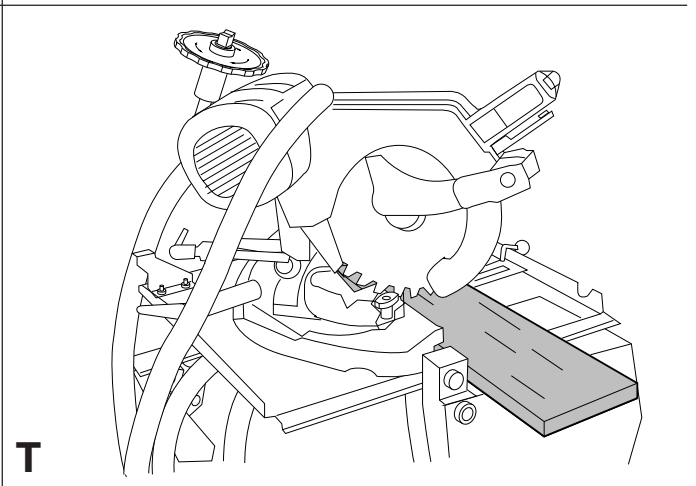
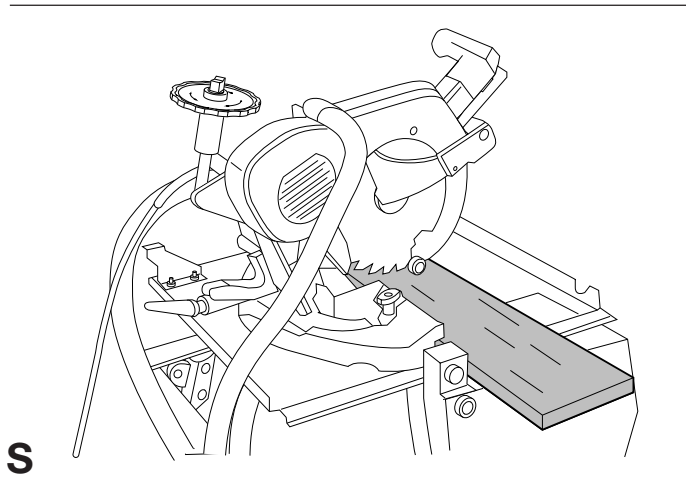
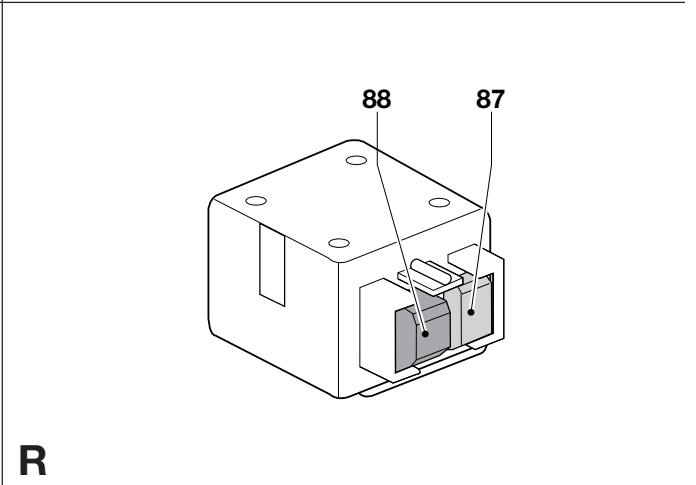
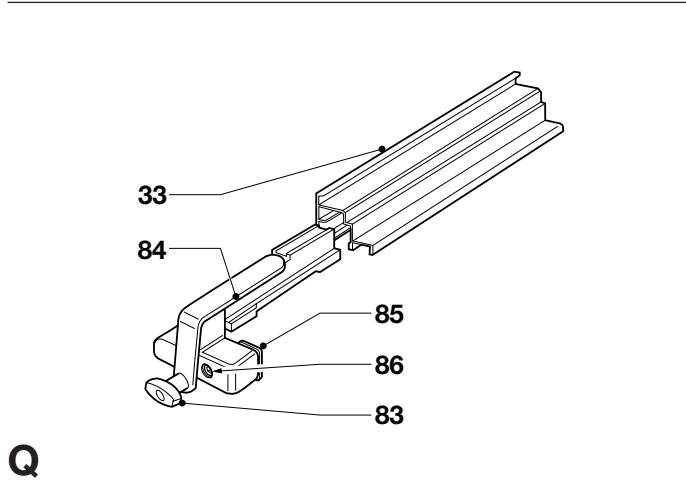
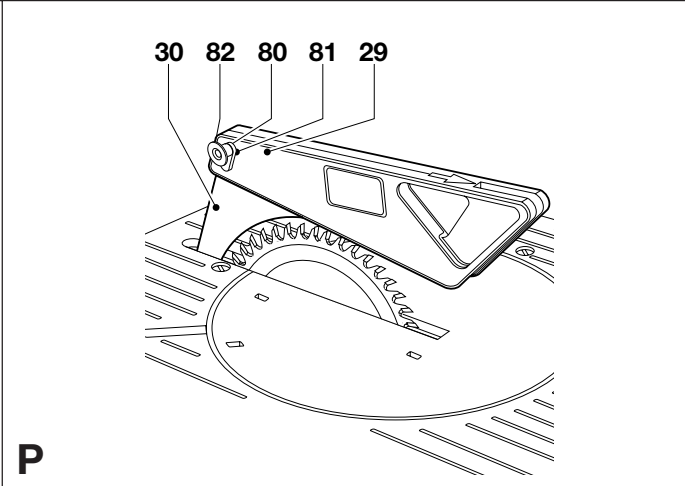
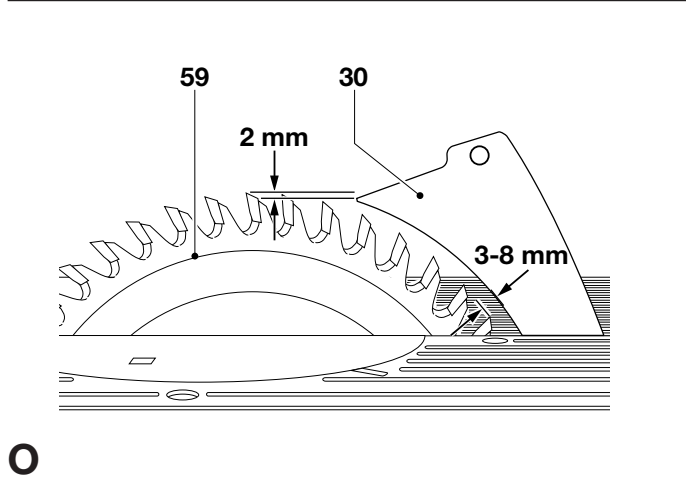
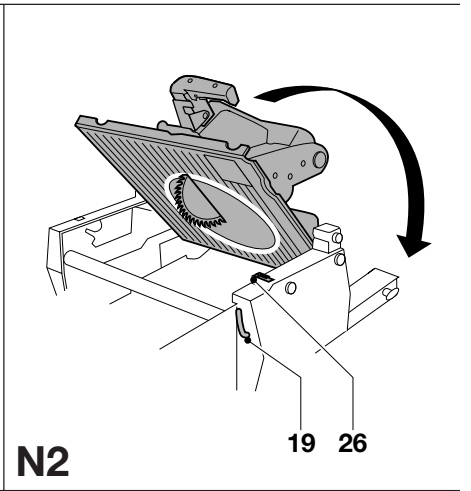
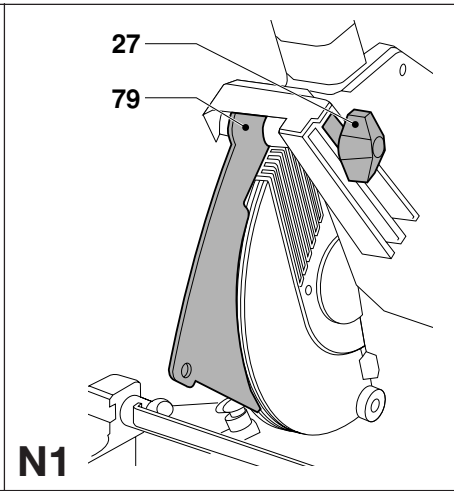
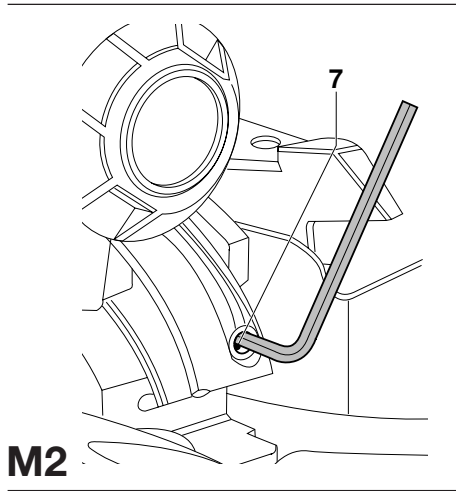

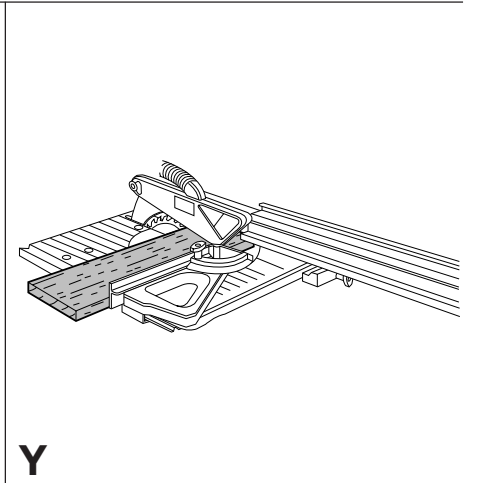
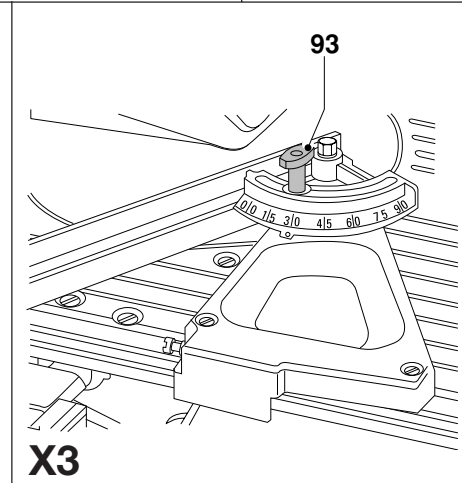
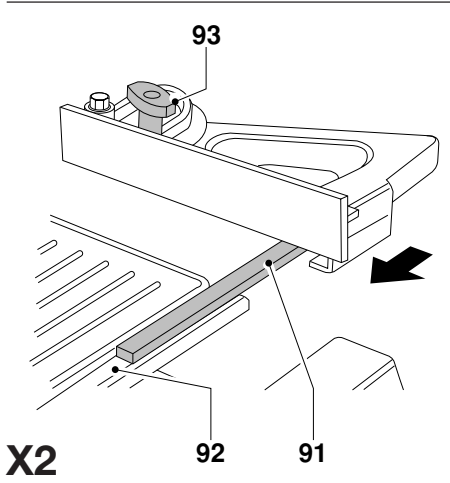
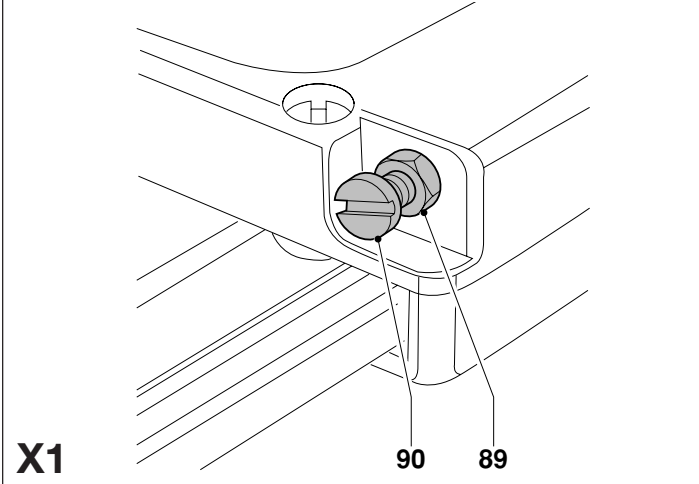
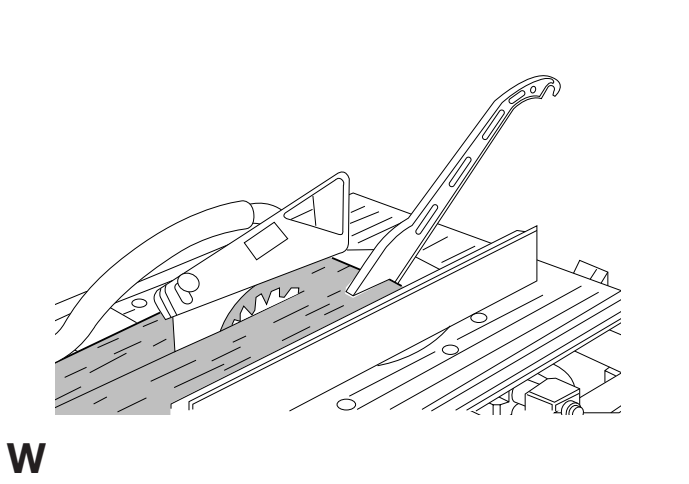
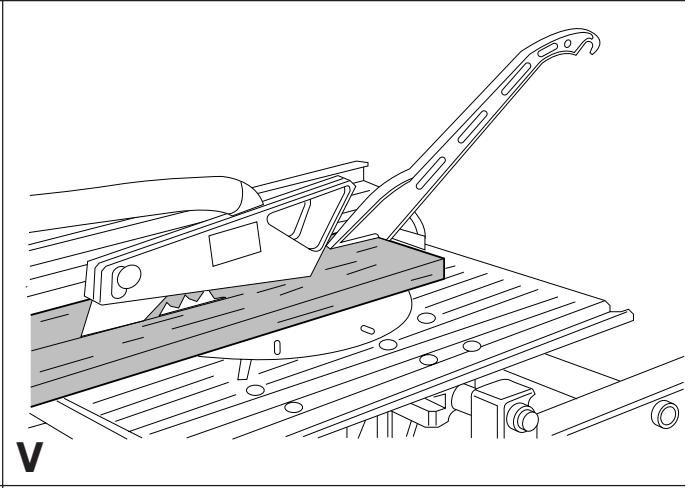
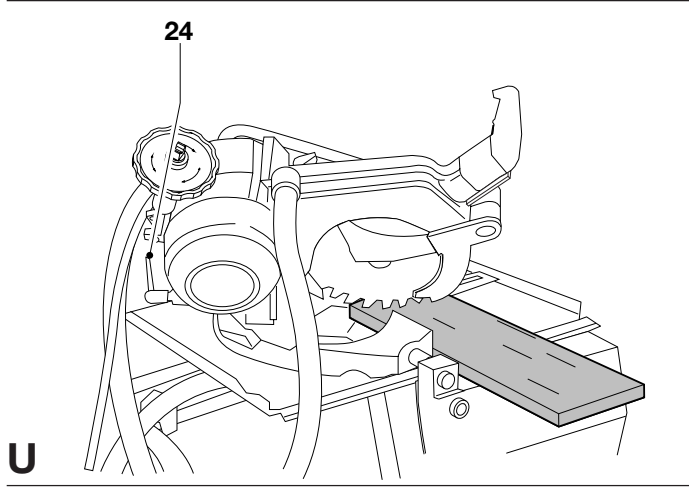

FLIP-OVER SAW DW743

Congratulations!

You have chosen a DeWALT product. Years of experience, thorough product development and innovation make DeWALT one of the most reliable partners for professional users.

Table of contents

Technical data	en - 1
EC-Declaration of conformity	en - 1
Safety instructions	en - 2
Package contents	en - 3
Description	en - 3
Electrical safety	en - 4
Mains plug replacement (U.K. & Ireland only)	en - 4
Using an extension cable	en - 4
Assembly and adjustment	en - 4
Instructions for use	en - 6
Maintenance	en - 8
Guarantee	en - 8

Technical data

	DW743	
Voltage	V	230
(U.K. & Ireland only)	V	230/115
(Latin America only)	V	120
Motor power (input)	W	1,650
Motor power (output)	W	1,100
Blade diameter	mm	250
Blade bore	mm	30
Max cycle of use load/no load	min	1/3
No-load speed (50/60 Hz)	min ⁻¹	3,000/3,600
Saw head pre-set locations left/right	°	0-45
Bevel adjustment	°	0-45
Cutting capacities	see under "Description"	
Weight	kg	38

Fuses:

Europe	230 V tools	10 Amperes, mains
U.K. & Ireland	230 V tools	13 Amperes, in plugs

The following symbols are used throughout this manual:



Denotes risk of personal injury, loss of life or damage to the tool in case of non-observance of the instructions in this manual.



Denotes risk of electric shock.



Sharp edges.

EC-Declaration of conformity



DW743

DeWALT declares that these Power Tools have been designed in compliance with: 98/37/EEC, 89/336/EEC, 73/23/EEC, EN 61029, EN 55014-2, EN 55014, EN 61000-3-2 & EN 61000-3-3.

For more information, please contact DeWALT at the address below or refer to the back of the manual.

Level of sound pressure according to 86/188/EEC & 98/37/EEC, measured according to DIN 45635:

	DW743	
L _{PA} (sound pressure)	dB(A)*	83
L _{WA} (acoustic power)	dB(A)	96

* at the operator's ear



Take appropriate measures for the protection of hearing if the sound pressure of 85 dB(A) is exceeded.

Weighted root mean square acceleration value according to DIN 45675:

	DW743	
	-	

TÜV Rheinland
Product and Safety GmbH (TRPS)
Am Grauen Stein 1
D-51105 Köln
Germany

	Cert. No.	
	BM 9910081 01	

Director Engineering and Product Development
Horst Großmann

DeWALT, Richard-Klinger-Straße 40,
D-65510, Idstein, Germany

Safety instructions

When using Power Tools, always observe the safety regulations applicable in your country to reduce the risk of fire, electric shock and personal injury. Read the following safety instructions before attempting to operate this product. Keep these instructions in a safe place!

General

- 1 Keep work area clean**
Cluttered areas and benches can cause accidents.
- 2 Consider work area environment**
Do not expose Power Tools to humidity. Keep work area well lit. Do not use Power Tools in the presence of flammable liquids or gases.
- 3 Guard against electric shock**
Prevent body contact with earthed surfaces (e.g. pipes, radiators, cookers and refrigerators).
For use under extreme conditions (e.g. high humidity, when metal swarf is being produced, etc.) electric safety can be improved by inserting an isolating transformer or a (FI) earth-leakage circuit-breaker.
- 4 Keep children away**
Do not let children come into contact with the tool or extension cord. Supervision is required for those under 16 years of age.
- 5 Extension cords for outdoor use**
When the tool is used outdoors, always use extension cords intended for outdoor use and marked accordingly.
- 6 Store idle tools**
When not in use, Power Tools must be stored in a dry place and locked up securely, out of reach of children.
- 7 Dress properly**
Do not wear loose clothing or jewellery. They can be caught in moving parts. Preferably wear rubber gloves and non-slip footwear when working outdoors. Wear protective hair covering to keep long hair out of the way.
- 8 Wear safety goggles**
Also use a face or dust mask in case the operations produce dust or flying particles.
- 9 Beware of maximum sound pressure**
Take appropriate measures for the protection of hearing if the sound pressure of 85 dB(A) is exceeded.
- 10 Secure workpiece**
Use clamps or a vice to hold the workpiece. It is safer and it frees both hands to operate the tool.
- 11 Do not overreach**
Keep proper footing and balance at all times.
- 12 Avoid unintentional starting**
Do not carry the plugged-in tool with a finger on the switch. Be sure that the switch is released when plugging in.
- 13 Stay alert**
Watch what you are doing. Use common sense. Do not operate the tool when you are tired.
- 14 Disconnect tool**
Shut off power and wait for the tool to come to a complete standstill before leaving it unattended. Unplug the tool when not in use, before servicing or changing accessories.
- 15 Remove adjusting keys and wrenches**
Always check that adjusting keys and wrenches are removed from the tool before operating the tool.
- 16 Use appropriate tool**
The intended use is described in this instruction manual. Do not force small tools or attachments to do the job of a heavy-duty tool. The tool will do the job better and safer at the rate for which it was intended.
Warning! The use of any accessory or attachment or performance of any operation with this tool, other than those recommended in this instruction manual may present a risk of personal injury.

- 17 Do not abuse cord**
Never carry the tool by its cord or pull it to disconnect from the socket. Keep the cord away from heat, oil and sharp edges.
- 18 Maintain tools with care**
Keep the tools in good condition and clean for better and safer performance. Follow the instructions for maintenance and changing accessories. Inspect the tool cords at regular intervals and, if damaged, have them repaired by an authorized DeWALT repair agent. Inspect the extension cords periodically and replace them if damaged. Keep all controls dry, clean and free from oil and grease.
- 19 Check for damaged parts**
Before using the tool, carefully check it for damage to ensure that it will operate properly and perform its intended function. Check for misalignment and seizure of moving parts, breakage of parts and any other conditions that may affect its operation. Have damaged guards or other defective parts repaired or replaced as instructed.
Do not use the tool if the switch is defective. Have the switch replaced by an authorized DeWALT repair agent.
- 20 Have your tool repaired by an authorized DeWALT repair agent**
This Power Tool is in accordance with the relevant safety regulations. To avoid danger, electric appliances must only be repaired by qualified technicians.

Additional safety rules for flip-over saws

- Do not use the saw to cut other than aluminium, wood or similar materials.
- Connect the machine to a dust collection device when sawing wood.
- Select the correct saw blade for the material to be cut.
- Use correctly sharpened blades. Observe the maximum speed marked on the sawblade.
- Use only saw blades recommended by the manufacturer and which conform to EN847-1.
- Make sure the floor area around the machine is level, well maintained and free of loose materials e.g. chips and off-cuts.
- Make sure adequate general or localized lighting is provided.
- Wear suitable personal protective equipment when necessary, including:
 - hearing protection to reduce the risk of induced hearing loss;
 - respiratory protection to reduce the risk of inhalation of harmful dust;
 - gloves for handling saw blades and rough material. Saw blades should be carried in a holder wherever practicable.
- Refrain from removing any cut-offs or other parts of the workpiece from the cutting area whilst the saw is running and the saw head is not in the rest position.
- Replace the table insert when worn.
- Report faults in the machine, including guards or sawblades, to your dealer as soon as they are discovered.
- Ensure that the upper portion of the saw blade is completely enclosed in the mitre sawing mode. Do not use the saw without the guards in position, in good working order and properly maintained.
- Ensure that the arm is securely fixed in the working position in the bench sawing mode.
- Ensure that the arm is securely fixed when bevelling in the bench saw mode.
- Take care when grooving during the bench saw operation by using appropriate guarding system. Slotting is not allowed.

Additional safety rules for mitre saws

- Make sure that the blade rotates in the correct direction. Keep the blade sharp. Do not use blades of larger or smaller diameter than recommended. For the proper blade rating refer to the technical data.
- Make sure all locking knobs and clamp handles are tight before starting any operation.
- Check periodically that the motor air slots are clean and free of chips.
- Disconnect the machine from the mains before carrying out any maintenance work or when changing the blade.
- Before using any accessory consult the instruction manual. The improper use of an accessory can cause damage.

- Allow the motor to reach full speed before cutting.
- Raise the blade from the kerf in the workpiece prior to releasing the switch.
- Do not wedge anything against the fan to hold the motor shaft.
- Never place either hand in the blade area when the saw is connected to the electrical power source.
- Do not attempt to cut excessively small pieces.
- Never attempt to stop a machine in motion rapidly by jamming a tool or other means against the blade; serious accidents can be caused unintentionally in this way.
- Do not use cracked or damaged saw blades.
- Do not use any abrasive discs.

Additional safety rules for saw benches

- Make sure that the blade rotates in the correct direction and that the teeth are pointing to the front of the saw bench.
- Be sure all clamp handles are tight before starting any operation.
- Be sure all blade and flanges are clean and the recessed sides of the collar are against the blade. Tighten the arbor nut securely.
- Keep the saw blade sharp and properly set.
- Make sure that the riving knife is adjusted to the correct distance from the blade - 3-8 mm.
- Never operate the saw without the upper and lower guards in place.
- Keep your hands out of the path of the saw blade.
- Disconnect the saw from the mains supply before changing blades or carrying out maintenance.
- Use a push stick at all times, and ensure that you do not place hands closer than 150 mm from the saw blade while cutting.
- Do not attempt to operate on anything but the designated voltage.
- Do not apply lubricants to the blade when it is running.
- Do not reach around behind the saw blade.

Residual risks

The following risks are inherent to the use of this saw:

- Injuries caused by touching the rotating parts
In spite of the application of the relevant safety regulations and the implementation of safety devices, certain residual risks cannot be avoided. These are:
- Impairment of hearing.
- Risk of accidents caused by the uncovered parts of the rotating saw blade.
- Risk of injury when changing the blade.
- Risk of squeezing fingers when opening the guards.
- Health hazards caused by breathing dust developed when sawing wood, especially oak, beech and MDF.

Package contents

The package contains:

- 1 Partly assembled machine
- 4 Legs
- 1 Top guard for bench saw position
- 1 Under-table guard for mitre saw position
- 1 Plastic bag containing:
 - 1 pin spanner
 - 1 Allen key 6 mm
- 1 Skinpack containing:
 - 1 dual height rip fence (DE3743)
 - 1 push stick
 - 1 30 teeth TCT saw blade
- 1 Instruction manual
- 1 Exploded drawing

- Check for damage to the tool, parts or accessories which may have occurred during transport.

- Take the time to thoroughly read and understand this manual prior to operation.
- Remove the saw from the packaging material carefully.

Description (fig. A1 - A4)

Your DEWALT flip-over sawing machine has been designed to operate as a mitre saw or as a saw bench to perform the four main sawing operations of ripping, cross-cutting, bevelling and mitring easily, accurately and safely, using the following materials: wood, wood products, aluminium and plastic.

Mitre saw mode

In mitre saw mode, the sawing machine is used in vertical, mitre or bevel position.

Saw bench mode

Turned over on its central axis, the sawing machine is used to perform the standard ripping operation and for sawing wide pieces by manually feeding the workpiece into the blade.

A1

- 1 On/off-switch
- 1A Trigger switch
- 2 Side panel
- 3 Leg clamping wingnut
- 4 Leg
- 5 Foot
- 6 Mitre saw table
- 7 Fence
- 8 Rotating table location plunger
- 9 Fixed lower rear guard
- 10 Fixed upper blade guard
- 11 Dust extraction adapter
- 12 Head lock release lever
- 13 Blade bolt
- 14 Outer flange
- 15 Moving lower guard
- 16 Rotating table
- 17 Rotating table clamp
- 18 Mitre scales
- 19 Table release lever

A2

- 20 Control handle
- 21 Depth stop rod
- 22 Height adjuster
- 23 Dust extraction adapter
- 24 Bevel clamp handle
- 25 Saw table retention bracket
- 26 Table locking device
- 27 Riving knife clamp knob
- 28 Motor housing

Saw bench mode

A3

- 29 Upper blade guard
- 30 Riving knife
- 31 Saw bench table
- 32 Mitre fence (optional)
- 33 Dual height parallel fence

Optional accessories

For use in mitre saw mode:

- A3
- 32 Mitre fence (DE3496)
- A4
- 34 Adjustable stand 760 mm (max. height) (DE3474)
- 35 Support guide rails 1,000 mm (DE3494)
- 35 Support guide rails 500 mm (DE3491)
- 36 Inclinable support (DE3495)
- 37 Swivelling stop (DE3462)
- 38 Length stop for short workpieces (to be used with guide rails [35]) (DE3460)
- 39 Support with removable stop (DE3495)
- 40 Support with stop removed (DE3495)
- 41 Material clamp (DE3461)

- A5
- 42 Roller support table (DE3497)

For use in saw bench mode:

- A6
- 43 Extension table (DE3472)
- A7
- 44 Single sliding table (DE3471)
- Push sticks (DE3454) (not shown)

For use in all modes:

- A8
- 45 Three way dust extraction kit (DE3500)

Cutting capacities

Cutting capacity in mitre saw mode			
Cutting angle	Size of material		Notes
	H mm	B mm	
Straight cross-cut	20	180	No packaging piece required
	30	176	
	40	170	
	68	140	
	85	68	
	88	22	With 25 mm packaging piece (fig. B1)
	15	210	With 50 mm packaging piece (fig. B1)
Thin boards only (fig. B2)			
Table turned 45° to right for mitre cuts			
	70	95	Cross-cut at max. height
Table turned 45° to left for mitre cuts			
	68	93	Cross-cut at max. height
Sawhead tilted 45°			
for bevel cuts	50	140	

Cutting capacity in saw bench mode		
Cutting depth adjustment		
90° vertical cut	0 - 70 mm	
45° bevel cut	0 - 32 mm	

Electrical safety

The electric motor has been designed for one voltage only. Always check that the power supply corresponds to the voltage on the rating plate.

Mains plug replacement (U.K. & Ireland only)

- Should your mains plug need replacing and you are competent to do this, proceed as instructed below. If you are in doubt, contact an DeWALT authorized repair agent or a qualified electrician.
- Disconnect the plug from the supply.
- Cut off the plug and dispose of it safely; a plug with bared copper conductors is dangerous if engaged in a live socket outlet.
- Only fit 13 Amperes BS1363A approved plugs fitted with the correctly rated fuse (1).
- The cable wire colours, or a letter, will be marked at the connection points of most good quality plugs. Attach the wires to their respective points in the plug (see below). Brown is for Live (L) (2), blue is for Neutral (N) (4) and green/yellow is for Earth (E).
- Before replacing the top cover of the mains plug ensure that the cable restraint (3) is holding the outer sheath of the cable firmly and that the leads are correctly fixed at the terminal screws.

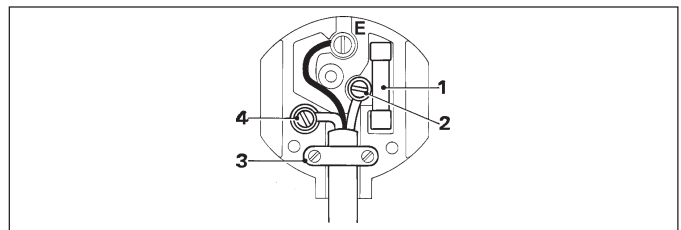

Never use a light socket. Never connect the live (L) or neutral (N) wires to the earth pin marked E or \perp .

Using an extension cable

If an extension cable is required, use an approved extension cable suitable for the power input of this machine (see technical data). The minimum conductor size is 1.5 mm². When using a cable reel, always unwind the cable completely. Also refer to the table below.

Conductor size (mm ²)	Cable rating (Amperes)						
0.75	6						
1.00	10						
1.50	15						
2.50	20						
4.00	25						
Cable length (m)							
	7.5	15	25	30	45	60	
Voltage	Amperes	Cable rating (Amperes)					
230	0 - 2.0	6	6	6	6	6	6
	2.1 - 3.4	6	6	6	6	6	6
	3.5 - 5.0	6	6	6	6	10	15
	5.1 - 7.0	10	10	10	10	15	15
	7.1 - 12.0	15	15	15	15	20	20
115-120	12.1 - 20.0	20	20	20	20	25	-

Assembly and adjustment



Prior to assembly and adjustment always unplug the tool.

The machine is packed in the saw bench mode for compactness and is fully assembled for mitre saw operation except for the legs, under-table plastic guard and blade.

Fitting the legs (fig. C)

- Place the machine upside down on the floor.
- Loosen the four wingnuts (3) and insert a leg (4) into each of the clamps.
- Tighten the wingnuts (3) and turn the table over. Make sure it is level; adjust the leg clamping height if required.

Assembly for mitre saw mode

Mounting the under-table guard (fig. D)

The under-table guard (48) is fitted to the top of the saw bench table.

- Place the two hooks on the left of the guard into the oblong slots (49) on the left of the blade slot (50).
- Place the guard flat on the table and press it in the locking grommet (51).
- To remove, loosen the grommet with a screwdriver (52) and proceed in reverse order.

Turning the sawhead and table over (fig. A2, E1 & E2)

- Withhold the saw table with one hand and push the table release lever (19) to the left (fig. E1).
- Push the table downwards at the front and swing it over completely until the motor assembly is uppermost and the indentation engages in the retaining teeth of the table locking device (26).
- The head assembly is held down by a clamp strap at the front and a height adjuster (22) at the rear (fig. A2).
- Remove the strap.
- Rotate the circular wheel (53) counterclockwise whilst holding down the head until the "U"-shaped bracket (54) can be disengaged from its seating (fig. E2).
- Swing the height adjuster up and push the rod (55) into the clip (56).
- Holding the head firmly, allow the spring pressure to take the head upwards into its rest position.

Mounting the saw blade (fig. A1, F1 - F3)



- The teeth of a new blade are very sharp and can be dangerous.
- Always change blades with the machine in mitre saw mode.
- The maximum diameter blade that can be fitted is 250 mm. The minimum diameter is 244 mm.

- Loosen the riving knife clamping knob (27) and allow the riving knife (30) to swing downwards (fig. F1).
- Place the 6 mm Allen key into the end of the blade bolt (13) and the two pins of the pin spanner (57) into the holes on the outer flange (14).
- The blade bolt has a left-handed thread, therefore holding the spanner firmly, turn the Allen key clockwise to loosen.
- Remove the blade bolt (13) and remove the outer flange (14).
- If the blade bolt is too tight, turn the handle of the pin spanner (57) into the guard and lock it there using a screwdriver (58) (fig. F2). This allows to exert extra pressure on the Allen key.
- The blade (59) has a 30 mm bore, and is located on a step flange (60) on the inner flange (61) (fig. F1).
- Press the guard retraction lever (12) and move the head down slightly to release the lower guard (15) (fig. A1).
- Rotate the lower blade guard all the way up and hold it there.
- Make sure the inner flange and both faces of the blade are clean and free of dust.
- Place the blade onto the step flange (60) on the inner flange (61), ensuring that the teeth are pointing downwards (fig. F1).
- Carefully ease the blade into position and release the lower blade guard.
- Also ensure that the two projections (62) on the outer collar are seated properly through the inner collar and onto the flats on the spindle.
- Tighten the blade bolt securely.
- Rotate the blade by hand to check that it rotates freely. If it fouls the lower rear blade guard (9), retighten the crosshead screws (63) (fig. F3).
- Reposition the riving knife (30) in the upper rest position and tighten the clamping knob (27) (fig. F1).

Adjusting the mitre saw mode depth limiter (fig. G)

The handle (64) is connected to a depth stop rod (21) which has an eccentrically positioned adjustable bolt (65) with locknut (66). When the depth limiter is engaged, the saw head cannot be pulled down completely (fig. G).

- Handle to the left = engaged, for use in mitre saw mode (all angles except 0-45° mitre cross cut)
- Handle to the right = disengaged, for use in saw bench mode
- If the depth limiter needs adjustment, loosen the locknut (66) and screw the bolt (65) in or out as required.



Incorrect use of the depth limiter may cause damage to the machine.

Adjusting the mitre angle in mitre saw mode (fig. A1, A2 & H)

The straight cross-cut and 45° mitre positions are pre-set.

- Lift the rotating table clamp (17), pull up the rotating table location plunger (8) and rotate it counterclockwise a quarter of a turn (fig. A1).
- Grip the control handle (20) (fig. A1), compress the guard retraction lever (12) and lower the saw about halfway (fig. A2).
- Turn the sawhead with its rotating table to the required position.
- Push down the rotating table clamp (17). The rotating table location plunger (8) will engage automatically (fig. A1).

Using the red marks (67), the rotating table (16) can be set to any mitre angle left or right between 0° and 45° (fig. H):

- angles between 0° and 30°: use the red marks nearest to the slot
- angles between 30° and 45°: use the outer red mark (68)
- Proceed as for pre-set positions. The rotating table location plunger cannot be used for intermediate angles.



Always make a trial cut in a piece of waste wood, to check for accuracy.

Adjusting the bevel position (fig. J)

The sawhead can be tilted from the vertical position to 45° left to enable bevel cuts to be made at any angle between these two limits.

- Standing behind the machine, release the bevel clamp handle (24) (it allows a ratchet-type action when full rotation of the handle is not possible).
- Tilt the sawhead to the required angle on the bevel scale (69). The pointer (70) is on the fixed cast part of the bevel bracket (71).
- Tighten the bevel clamp handle (24) and leave it in horizontal position.

Checking and adjusting the blade to the fence (fig. H2, K1 & K2)

- With the head in the vertical position and the bevel clamp handle (24) released and raised, slacken the locking screw (72) in the rear of the rotating table location plunger (8) (fig. K1).
- Place a set square (73) against the fence and along the blade as shown in figure K2. The angle should be 90°.
- If adjustment is required, rotate the eccentric adjustment bush (74) until the face of the saw blade is flat against the square (fig. K2).
- Tighten the locking screw (72).
- Check that the red marks (67) nearest the blade slot (50) are in line with the 0° position (75) on the two scales (fig. H).
- If adjustment is required, loosen the screws (76) and bring the indicators in line. The 45° position should now also be accurate. If this is not the case, the blade is not perpendicular to the rotating table (see below).

Adjusting the blade vertical to the rotating table (fig. L1 & L2)

- Ensure that the sawhead is to its extreme right-hand position with the bevel clamp handle locked.
- Release and retract the lower guard.
- Place a set square (73) on the rotating table and up against the blade (fig. L1).
- If adjustment is required, proceed as follows:
- Adjust the grub screw (77) as required. The grub screw is self-locking (fig. L2).

Checking and adjusting the 45° bevel position in mitre mode (fig. M1 & M2)

- Ensure that the sawhead is to its extreme left-hand position with the bevel clamp handle locked.
- Release and retract the lower guard.
- Check the angle from the blade to the table with a suitable protractor. It should be 45° (fig. M1).
- If adjustment is required, proceed as follows:
- Adjust the grub screw (78) as required. The grub screw is self-locking (fig. M2).

Assembly for saw bench mode

Changing from mitre saw to saw bench mode (fig. A1, A3, E2, G, N1 & N2)



Check that the depth limiter is disengaged. Refer to the section "Adjusting the mitre saw mode depth limiter (fig. G)".

- Put the blade into 0° cross-cut position with the rotating table location plunger (8) correctly located and the rotating table clamp (17) secured (fig. A1).
- Slacken the riving knife clamp knob (27) just enough to allow the riving knife to swing downwards (fig. N1).
- Slide the riving knife bracket (79) to the right so that the narrow part on the right locates in the slot provided in the casting and tighten the clamp knob.
- Remove the under-table guard.
- Pull down the sawhead and swing the height adjuster (22) until its U-shaped bracket (54) engages on the pin provided in the base (fig. E2).
- Turn the wheel (53) of the adjuster to make the blade and riving knife protrude from the saw bench table (31) (fig. A3) to provide maximum cutting depth in saw bench mode.



The blade should not foul the lower blade guard.

- Pull the table release lever (19) to the left, lift the front edge of the table and flip it back through 180° until the teeth of the table-locking device (26) automatically engage the saw blade retention lever to secure it in the saw bench mode (fig. N2).

Adjusting the riving knife (fig. A2, F3 & O)

In the mitre saw mode, the riving knife (30) must be adjusted up and out of the way by unscrewing the clamp knob (27) and moving the riving knife until it can be rotated up (fig. F3).

In the saw bench mode, the correct position is for the top of the riving knife (30) to be no more than 2 mm below the highest tooth of the blade (59) and the body of the radius to be a maximum of 3-8 mm from the tips of the saw blade teeth. Also the riving knife must be completely in line with the rear of the saw blade (fig. O).

- If adjustment is required, proceed as follows:
- Unlock the clamp knob (27), slide the knob forwards or backwards in its slot and tighten the clamp knob (fig. A2).



- The bracket securing the riving knife to the machine must be at least 3 mm away from the blade teeth.
- Always check that the riving knife clamp knob is tightly secured.

Fitting the upper blade guard (fig. P)

The upper blade guard (29) is designed to be quickly and easily attached, via a spring-loaded plunger (80) to the hole (81) in the riving knife (30) once it has been positioned through the worktable for saw bench mode.

- Secure the upper blade guard (29) to the riving knife by pulling the knob (82) to allow the plunger in the guard to engage.



Never use your saw in saw bench mode without the upper guard correctly fitted.

Mounting and adjusting the parallel fence (fig. Q)

The dual height parallel fence (33) can be used in two positions (10 or 62 mm). The parallel fence can be mounted on either side of the blade. To turn the fence into the appropriate position, proceed as follows:

- Loosen the knob.
- Pull out the bracket (84) and replace it on the other end.
- Slide the bracket on from the left or the right. The clamping plate (85) engages behind the front edge of the table.
- Check that the fence is parallel to the blade. If not, then adjust as follows.
- Loosen the Allen screw (86).
- Adjust the fence so that it is parallel to the blade by checking the distance between the blade and the fence at the front and rear of the blade.
- When the adjustment has been carried out, re-tighten the Allen screw and check again that the fence is parallel to the blade.
- Tighten the knob (83).



- Use the 10 mm profile for ripping low workpieces to allow access between the blade and the fence for the push stick.
- The rear end of the fence should be level with the front of the riving knife.

Changing from saw bench to mitre saw mode (fig. D, E1 & E2)

- Remove the parallel fence (33).
- Turn the wheel (53) of the height adjuster (22) to provide maximum cutting depth in mitre saw mode (fig. E2).
- Proceed as described in the section "Turning the sawhead and table over (fig. E1 & E2)".
- Adjust the riving knife up and out of the way.
- Replace the under-table guard (48) (fig. D).



Remember to use the depth stop limiter for all angles except 0-45° mitre cross cut.

Instructions for use



- Always observe the safety instructions and applicable regulations.
- The attention of UK users is drawn to the "woodworking machines regulations 1974" and any subsequent amendments.
- Ensure the material to be sawn is firmly secured in place.
- Apply only a gentle pressure to the tool and do not exert side pressure on the saw blade.
- Avoid overloading.

Prior to operation:

- Install the appropriate saw blade. Do not use excessively worn blades. The maximum rotation speed of the tool must not exceed that of the saw blade.
- Do not attempt to cut excessively small pieces.
- Allow the blade to cut freely. Do not force.
- Allow the motor to reach full speed before cutting.
- Make sure all locking knobs and clamp handles are tight.

Switching on and off (fig. A1)

This machine has two independent switching systems. In saw bench mode, the on/off switch (1) is used. In mitre saw mode, the trigger switch (1A) is used (fig. A1).

Saw bench mode (fig. R)

The on/off switch used in saw bench mode has a no-volt release function: should the power be shut off for some reason, the switch has to be deliberately reactivated.

- To switch the machine on, press the green start button (87).
- To switch the machine off, press the red stop button (88).

Mitre saw mode (fig. A)

- To switch the machine on, keep the guard retraction lever (12) squeezed and press the trigger switch (1A).
- To switch the machine off, release the trigger switch.

Basic saw cuts

Sawing in mitre saw mode

It is dangerous to operate without guarding. Guards must be in position when sawing. Always clamp the workpiece when cutting non-ferrous metals. Use the DE3461 clamp.

General handling

- In the mitre saw mode, the sawhead is automatically locked in the upper "park"-position.
- Squeezing the head lock release lever will unlock the sawhead.
- Never seek to prevent the lower guard returning to its park position when the cut is completed.
- The minimum length of offcut material is 10 mm.
- When cutting short material (min. 190 mm to the left or the right of the blade), the use of the optional material clamp is recommended.
- When cutting UPVC sections, a supporting piece made out of timber with a complementary profile should be placed beneath the material being cut to provide the correct level of support.

Vertical straight cross cut (fig. S)

- Set the rotating table to 0° and make sure that the locating plunger is engaged.
- Pull down the rotating table clamping knob.
- Place the wood to be cut against the fence. Take hold of the control handle and press in the head lock release lever.
- Switch the machine on.
- Allow the blade to cut freely. Do not force.
- When the cut is completed, raise the sawhead to its rest position and press the red stop button.



Do not allow the sawhead to jump back unaided to prevent damage.

Mitre cuts (fig. T)

- Set the required mitre angle.
- Ensure that the rotating table clamp is tightly secured.
- Ensure that the depth stop limiter is correctly set to prevent the blade cutting the table if the angle is not 45°.
- Proceed as for a vertical straight cross-cut.

Bevel cuts (fig. U)

- Release the bevel clamp handle (24) and tilt the head to the angle required.
- Tighten the bevel clamp handle.
- Proceed as for a vertical straight cross-cut.

Compound mitre

This cut is a combination of a mitre and a bevel cut.

The limitations are 45° mitre/30° bevel. Do not exceed these limits.

- Set the bevel angle and subsequently set the mitre angle.

Sawing in the bench mode

- Always ensure that the riving knife and blade guard are correctly aligned.

Ripping (fig. V)

- Set the blade to the correct height.
- The correct blade position is to have the tips of three teeth above the top surface of the wood.
- Mount the parallel fence using either the 10 mm or the 62 mm profile. The piece of wood between the fence and the blade is the retained piece.
- Switch the machine on.
- Slowly feed the timber underneath the front of the upper blade guard, keeping it firmly pressed against the fence. Allow the teeth to cut and do not force the timber through the blade. The blade speed should be kept constant.



Always use a push stick.

- When the cut is finished, switch off by pressing the red stop button.

Bevel cuts (fig. W)

- Release the bevel clamp handle and set the blade to the required angle.
- In order to prevent material jamming between the blade and the fence, position the fence to the left of the blade.
- Proceed as for vertical ripping.

Mitre cuts (fig. X1 - X3)

- To adjust the mitre fence, loosen the stop screw locknut (90) and screw the stop (91) in or out until the mitre pointer reads 0° (fig. X1).
- Set the blade height and angle.
- Insert the slide bar (92) of the mitre fence into the groove (93) provided in the left-hand side of the table (fig. X2).
- Loosen the mitre locking knob (94) and rotate the fence to set the scale to the required angle (fig. X3).
- Tighten the mitre locking knob (94).
- Place the workpiece against the flat surface of the mitre fence. Switch on and, holding the workpiece firmly, slide the fence along the groove to take the workpiece into the blade. When the cut is completed, switch off immediately.

Fence positions, saw bench mode (fig. Y)

- For ripping thin materials, use the 10 mm profile of the dual height parallel fence and position the fence opposite the front edge of the riving knife.
- For ripping thicker materials, use the 62 mm profile of the dual height parallel fence.
- For cross-cutting narrow and short workpieces (fig. Y):
 - Adjust the parallel fence with the low profile facing the blade and install the rear of the fence in line with the leading edge of the blade.
 - Set the workpiece against the mitre fence (at 0° or 90°) and push the mitre fence to make the cut.
 - To prevent small offcut pieces fouling against the blade, prepare a tapered length of timber and clamp it on the rear edge of the worktable close enough to the right-hand side of the blade so that successive offcuts feed automatically to the right.
- For ripping narrow (< 120 mm) and long workpieces:
 - Place the fence in rearmost position to maintain accuracy during long cuts.
 - Push the workpiece with both hands (one on each side of the blade).
 - Use a push stick when close to the blade.
 - Support long workpieces at the outfeed side.
- For ripping wider (>120 mm) workpieces:
 - Adjust the fence forward as in figure Y if the material being cut tends to jam between the blade or the riving knife and the fence.

Optional accessories



Prior to assembling any accessories always unplug the machine.

Dust extraction kit (fig. A1, A2 & A8)

This machine is provided with three dust extraction points for use in each mode.

- Whenever possible, connect a dust extraction device designed in accordance with the relevant regulations regarding dust emission.

Connecting - mitre saw position

- Connect one hose to the under-table guard.
- Connect one hose to the small diameter outlet (11) and one to the large diameter outlet (23) using the corresponding spouts.
- Connect the hoses to the 3-way connector.
- Connect the single outlet of the 3-way connector to the hose from the dust extractor.

Connecting - saw bench position

- Replace the saw blade guard by the guard supplied with the dust extraction kit and connect the hose from the under-table guard to it.
- Proceed as for mitre saw position.

Mitre saw extra support/length stop (fig. A4)

The extra support and length stop can be mounted on the left-hand side or on the right-hand side, or with two sets on either side.

- Fit the items 34 - 41 onto the two guide rails (35).
- Use the inclinable support (36) for cross-cutting 210 mm wide boards (15 mm thick).

Roller support table (fig. A5)

In mitre saw mode, the roller support table can be mounted on the left-hand side or on the right-hand side, or with two sets on either side. In saw bench mode, it can also be mounted in front or at the rear of the saw table.

Side extension table (fig. A6)

The side extension table increases the distance from the rip fence to the blade to 600 mm or more, depending on the rod length fitted to the machine and the clamped position of the table.

The side extension table must be used in conjunction with guide rails (35) (option). The adjustable table is equipped with an engraved scale along its front edge and mounted on a sturdy base which clamps to the guide rods.

- Fit the extension table to the right-hand side of the machine for continuity of the distance scale on both tables.

Single sliding table (fig. A7)

This sliding table (44) allows for board sizes to the left of the blade up to 1200 x 900 mm.

The guide rods are mounted on a sturdy alloy extrusion which is quickly detachable from the machine and yet fully adjustable in all planes.

The fence incorporates a full length measuring tape for quick positioning of an adjustable stop and an adjustable support for narrow workpieces.

Transporting

Always transport your saw in saw bench mode with the upper blade guard fitted. Remove the legs.

Maintenance

Your DeWALT machine has been designed to operate over a long period of time with a minimum of maintenance. Continuous satisfactory operation depends upon proper tool care and regular cleaning.



Lubrication

The bearings of the motor are pre-lubricated and watertight.

- Slightly oil the rotating table bearing surface where it slides on the lip of the fixed table at regular intervals.
- Clean the parts subject to accumulation of sawdust and chips periodically with a dry brush.



Unwanted tools and the environment

Take your tool to an authorized DeWALT repair agent where it will be disposed of in an environmentally safe way.

GUARANTEE

• 30 DAY NO RISK SATISFACTION GUARANTEE •

If you are not completely satisfied with the performance of your DeWALT machine, simply return it within 30 days, complete as purchased, to the point of purchase, for a full refund or exchange. Proof of purchase must be produced.

• ONE YEAR FREE SERVICE CONTRACT •

If you need maintenance or service for your DeWALT machine, in the 12 months following purchase, it will be undertaken free of charge at an authorized DeWALT repair agent. Proof of purchase must be produced. Includes labour and spare parts for Power Tools. Excludes accessories.

• ONE YEAR WARRANTY •

If your DeWALT product becomes defective due to faulty materials or workmanship within 12 months from the date of purchase, we guarantee to replace all defective parts free of charge or, at our discretion, replace the unit free of charge provided that:

- The product has not been misused.
- Repairs have not been attempted by unauthorized persons.
- Proof of purchase date is produced.

This guarantee is offered as an extra benefit and is additional to consumers statutory rights.

For the location of your nearest authorized DeWALT repair agent, please use the appropriate telephone number on the back of this manual. Alternatively, a list of authorized DeWALT repair agents and full details on our after-sales service are available on the Internet at www.2helpu.com.