



User Guide



Scaffold Trolley

Permaquip Ltd
Brierley Industrial Park, Stanton Hill,
Sutton-In-Ashfield, Nottinghamshire, NG17 3JZ
Tel: +44 (0) 1623 513349
Fax: +44 (0) 1623 517742
E-mail: sales@permaquip.co.uk
www.permaquip.co.uk

CONTENTS

1	Issue and Revision Record	3
2	Introduction	4
3	Safe and Correct Use.....	4
4	Technical Specification.....	6
4.1	Physical Data for the Scaffold Trolley.....	6
4.2	Specification.....	6
4.3	Product Compliance.....	6
5	General Layout.....	7
6	Operating Instructions	8
6.1	Mounting on the Track	8
6.2	Moving the Tower.....	10
6.3	Dismantling the Tower	11
7	Maintenance	12
7.1	General.....	13
7.2	Shift Maintenance	14
7.3	Weekly Maintenance.....	14
7.4	Monthly Maintenance.....	15
7.5	Three Monthly Maintenance.....	15
7.6	Six Monthly Maintenance	15
8	Test Specification.....	16
9	Training.....	17
10	Ordering.....	18
10.1	Main Components and Assemblies.....	18

Please note

Whilst Permaquip Limited has taken every care in preparing this User Guide it is intended as a technical guideline only. Save to the extent that there are statutory rights to the contrary, Permaquip accepts no liability in relation to any use or reliance made of any information in this User Guide.

All information, illustrations and specifications in this User Guide are based on the latest information available at the time of publication. The right is reserved to make changes at any time without notice.

Equipment operators and installers shall be responsible for ensuring that a safe working environment and safe systems of work are in place and in certain circumstances advice and permission from the controlling authority must be sought before any operation, installation or surveying work is carried out.

Permaquip™ is a trademark of Permaquip Ltd.
©2006 Permaquip Ltd.

2 INTRODUCTION

The Permaquip™ Scaffold Trolley is designed for use on-track in conjunction with the Boss Zone 1 1450 x 1.8/2.5 (fibreglass construction) and the Boss Ladderspan or Staircase 1450 x 1.8/2.5 (aluminium construction) tower systems to access areas above the rail head.

Each Scaffold Trolley is equipped with a fail-safe braking system and is supplied with Brake Handles.

3 SAFE AND CORRECT USE

Please keep this User Guide for future reference.

To ensure safe and correct use of the Scaffold Trolley the following should be noted:



Wear head, feet and hand protection when using the Scaffold Trolley. Additional Personal Protective Equipment (PPE) should be worn according to local regulations.



During transit the Scaffold Trolley should be secured, and kept away from all electrified lines. Ensure that any method used to secure the Scaffold Trolley in/on a vehicle applies the load uniformly and does not exceed the SWL. Do not use excessive force when using a ratchet type loading strap.



The Scaffold Trolley, or parts of, must be replaced if damage occurs. Do not use the Scaffold Trolley if any components are damaged.



Store the Scaffold Trolley in a secure position.



Ensure that when utilising the side cantilever extension platforms (aluminium tower only), the Boss SP7 stabiliser legs are deployed on both sides of the tower as per the Boss Instruction Manual. Ensure that the stabiliser feet are set onto firm ground – use suitable packing (such as timber) of at least 200 mm square when loaded onto ballast. Counterweights on SGB Boss towers are not required when the cantilevered platform comes within the footprint of the stabilisers.



Stopping distances will greatly increase by icy or wet conditions; gradients; an increase in load; an increase in speed.



Before using, undertake a Manual Handling Risk Assessment and follow the assessment guidelines at all times. Do not exceed walking pace, noting underfoot and rail head conditions. Do not walk on sleepers or the rail head.



Ensure that when preparing for work and packing away, the adjacent lines shall be under the control of the Engineering Supervisor responsible for controlling movements of vehicles.



Equipment must be used in accordance with Railway Group Standard GM/RT1403.



Ensure that two persons are employed to move the Scaffold Trolley when assembled.



Only use the Scaffold Attachment as described in the Introduction and ensure that the scaffolding is certified to BS1139 Part 3 or equivalent.



It is recommended that tubes and couplers are fitted to link all the frames of the tower assembly on the side opposite the cantilever (both sides where a cantilever is fitted to both sides) to prevent the possibility of the joints pulling apart under the cantilever load.



The Scaffold Trolley is limited to works of a light duty, with low impact nature, using only non-powered inspection hand tools whilst the scaffold trolley is on a maximum cant of 50mm with a working platform height of 4m.



Do not use the Scaffold Trolley for any other purpose than as described in the introduction.



Equipment is not permitted outside a possession.



Do not propel or tow the Scaffold Trolley.



Do not use the Scaffold Trolley on or near live AC overhead power lines, or DC third-rail or fourth-rail systems.



Do not overload the tower. All items of equipment and materials must be contained within the floor area.

4 TECHNICAL SPECIFICATION

4.1 Physical Data for the Scaffold Trolley

	Trolley Assembly
Width	1700 mm (when assembled)
Length	2.56 m or 3.14 m
Height	570 mm (without tower unit)
Total Mass	40 kg (each side)
Centre of mass	Central

4.2 Specification

- Maximum platform height above track (max cant 50mm) 4 m
- Maximum cant 150 mm
- Maximum SWL on main platform without ballast 225 kg
- Maximum SWL with 200 kg ballast UDL on lower deck 300 kg
- Maximum SWL with side cantilever extension platforms 150 kg
- Maximum speed on rail (hand manoeuvred only) 3 mph
- Maximum speed through P&C (hand manoeuvred only) 3 mph
- Length specification of Scaffold Units that can be used 1.8 m or 2.5 m

4.3 Product Compliance

The Scaffold Trolley complies with RIS-1701-PLT.

5 GENERAL LAYOUT

The following shows the main components of the Scaffold Trolley.

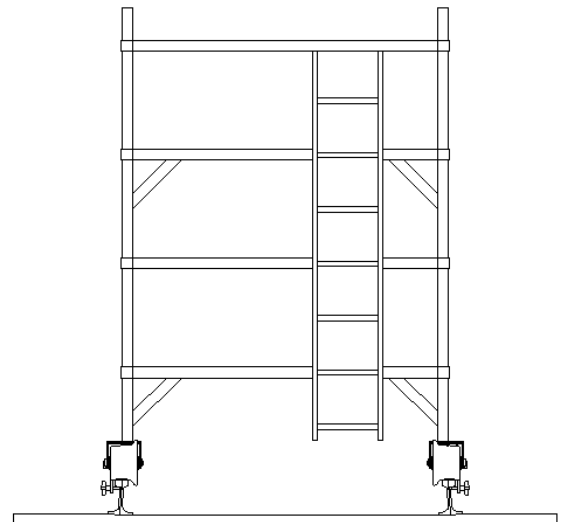
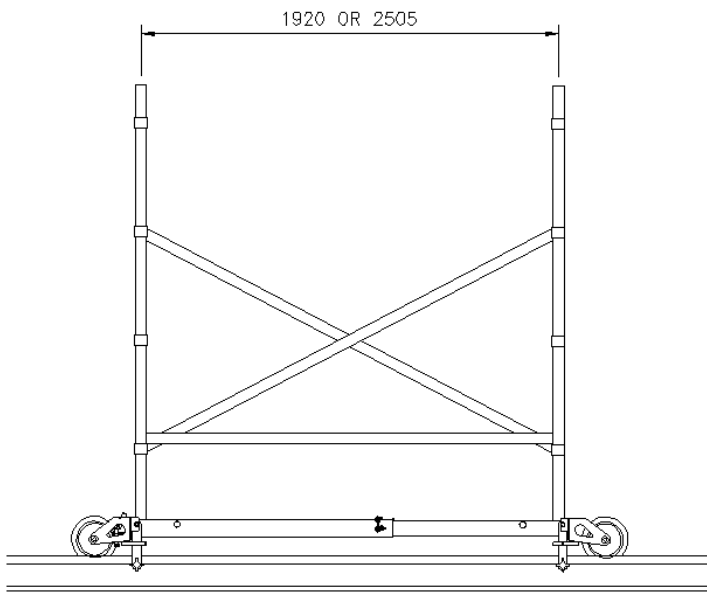
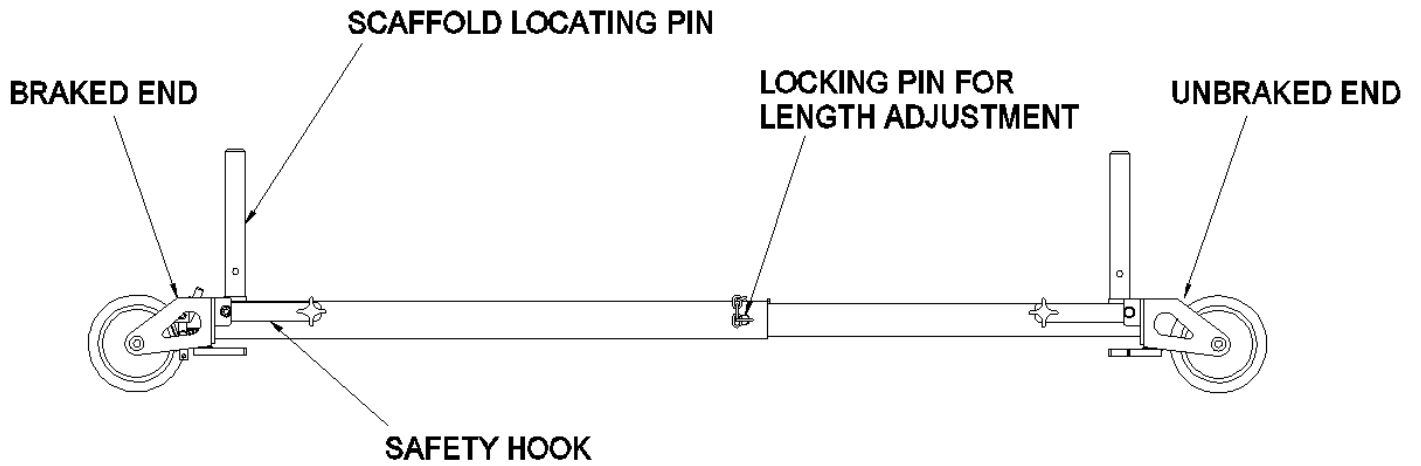

6 OPERATING INSTRUCTIONS

The following procedure outlines the correct method for operation.



All work should only be performed by competent personnel.



Always follow local regulations.



Observe Manual Handling Regulations.

6.1 Mounting on the Track

1. The Scaffold Trolley should be assembled by a minimum of two persons.
2. Check that both Scaffold Trolley halves have the same serial number, are identified with the SWL and the 'Next Brake Test Due' has not expired.
3. Check that the brakes are in good working order. To do this, access the braked wheels and rotate with one hand. The wheels should resist movement. If in doubt do not use until it has been checked by a competent person.
4. On level ground, take two Scaffold Trolley units and place them approximately 1.5 m apart, adjacent to each rail.
5. Remove the Locking Pin located halfway along the Sliding Leg and adjust the Scaffold Trolley length to suit the length of scaffolding being used, as shown below.

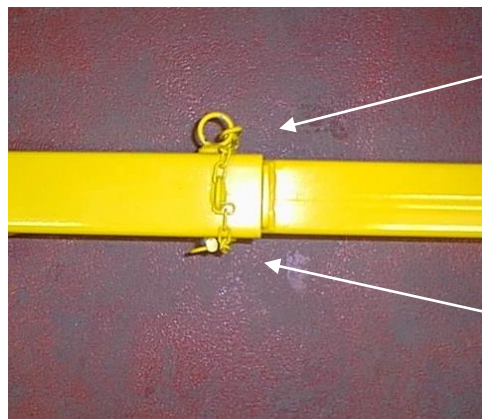

Locking
Pin

Antiluce
Clip

6. Replace the Locking Pin and secure in place using the Antiluce clip.
7. Place an offset ladder frame at one end and a normal span frame at the other, using suitable cross-bracing, to create a self-supporting structure. Refer to the SGB manual for instructions.

8. Ensure that the scaffold leg pins are in place.
9. Lift the assembly onto the rail, ensuring the wheels are fully located onto the rail head.
10. Undo the Screw Handle Locking Pins and lower the Safety Hooks. Retighten the Safety Screws until they press onto the rail web, as shown below.



11. Repeat at all four corners.
12. Construct the Scaffold Tower according to the SGB manual.

6.2 Moving the Tower



Always ensure that two personnel are employed to move the tower.



Ensure all loads are removed from the tower before moving.



Do not move the Scaffold Link Trolley while persons are on the platform.

1. Release the Safety Hooks and move them to their stowed position.
2. Place the Brake Handle onto each of the Brake Release Levers, as shown below.



3. Each operator should then move the Brake Handle to release the Brake. The tower assembly can then be moved to the required position.
4. Once the desired position is reached, release the Brake Handle to allow the fail-safe brakes to engage.
5. When moving the tower assembly with stabilisers (if fitted) – release the stabiliser legs and rotate in towards the track, sliding the stabilisers upwards if necessary until the stabilisers clear the rail head. Relock the stabilisers in line with the rail before placing the Safety Hooks in their stowed position.

6.3 Dismantling the Tower



Ensure all loads are removed from the tower before dismantling.

1. The Scaffold Trolley should be dismantled by a minimum of two persons.
2. This procedure is the reversal of that required to mount onto the track.
3. Ensure that the Safety Hook Safety Screws are fully engaged against the rail web; dismantle the tower except the lowest section.
4. Disengage the Safety Hooks from the rail and rotate them to their stowed position.
5. Remove the Scaffold Trolley from the rail and dismantle the lower section.

7 MAINTENANCE

For components that require replacing please refer to the Scaffold Trolley Spare Parts List. Please contact Permaquip Ltd for additional copies.

Note that:

- **The Maintenance and Testing of the Brakes, Wheels and Axles are defined as Railway Safety Critical under CoP0010, Railway Safety Critical Maintenance Elements of Small Plant and Equipment.**
- **The Maintenance and Testing of the Brakes are covered under CoP0018, Rail Mounted Manually Propelled Equipment. The brakes must be maintained and tested at a periodicity of no greater than 3 months.**



All work should only be performed by competent personnel. Qualifications to be Time Served Apprentice, N.V.Q. trained, or persons adjudged qualified to perform allotted tasks by the machine owner. All staff to have undergone the training course for the appropriate Permaquip equipment, to the extent of the responsibilities and the tasks they are asked to perform by the machine and equipment owners and their agents. Special equipment required is listed in the maintenance lists.



Always follow local regulations.



Observe Manual Handling Regulations.



Brake tests must be performed following any repair or replacement of the brake system or components, including brake pad replacement.
Note that the Scaffold Trolley is fitted with non-adjustable brakes.

Note

All maintenance tasks recommended for completion on site can also be performed with the equipment located within a workshop. The maintenance schedules contained within this document should be copied prior to completion and the completed sheet stored at the rear of the product folder. Do not record information directly onto this document.

7.1 General

Maintenance action is intended to ensure the continued safe operation of the Scaffold Trolley. The maintenance programme has been derived from reliability and safety apportionment's and failure by the owner to follow these activities would invalidate both warranty and safety systems given for the product.

The maintenance location defines the recommended position of the access unit for completion of maintenance actions. Subject to component access, maintenance actions can be completed in the five following locations:-

7.1.1 On Site

Here all maintenance action of examination and repair/replacement of the component(s) can be completed with the access unit on site.

7.1.2 Examination on Site, Replacement in Workshop

Here the visual examination of the component can be completed with the vehicle on site, but it is recommended that the maintenance actions take place in workshop conditions.

7.1.3 Workshop

Here the component is not readily visible/ accessible when fitted to the vehicle. It is recommended that the maintenance and examination of these components is carried out in a suitable workshop.

7.1.4 Examine at time of Overhaul

Here the component is assessed not to require general maintenance (i.e. sealed bearings) and the item is planned for repair or replacement within the overhaul schedule.

7.1.5 On Equipment, replaced through LRU

Here the component cannot be inspected on vehicle and can only be assessed using specialist equipment. The component is therefore assessed as a line replaceable unit (LRU) which will be offered on an exchange basis only.

7.2 Shift Maintenance

Maintenance Task	Instruction	Location	Pass/Fail Criteria	Carried Out by	Date	Audited by
Check Condition of Trolley	Check for damage or corrosion	On site	No obvious damage/ loose or missing fastenings	N/A		
Check Operation of brake mechanism	Check for any signs of damage or excessive wear	On site	Correct operation	N/A		
Examine wheels	Check for any signs of damage or excessive wear	On site	No obvious damage/ loose or missing fastenings	N/A		
Examine safety hooks	Check for any signs of damage or excessive wear	On site	Correct operation	N/A		
Examine Scaffold tower locking pins and structure	Examine all fastening pins and locking clips between each tower section and the scaffold trolley base unit for any signs of damage or poor locking action	On site	Correct operation No obvious damage/ loose or missing fastenings	N/A		

7.3 Weekly Maintenance

Maintenance Task	Instruction	Location	Pass/Fail Criteria	Carried Out by	Date	Audited by
Carry out Shift Maintenance		On Site	Replace any damaged or worn or incorrectly functioning parts			
Check sliding surfaces of RHS are greased	Use general purpose grease	On site	Correctly greased			
Check condition of main base assemblies for any signs of damage	Check all pins and clips and their mating holes and main frames are free from damage or corrosion		Replace any damaged or worn or incorrectly functioning parts			

7.4 Monthly Maintenance

Maintenance Task	Instruction	Location	Pass/Fail Criteria	Carried Out by	Date	Audited by
Carry out Weekly Maintenance		On site	Replace any damaged or worn or incorrectly functioning parts			
Examination of wheels	Visual inspection	On site	No obvious damage / excessive play in wheel			
Check operation of brakes	For signs of damage / excessive wear	On site	Replace any suspect parts immediately			
Check condition of brake pads	Minimum thickness of 2.5mm	On site	Replace as required			

7.5 Three Monthly Maintenance

Maintenance Task	Instruction	Location	Pass/Fail Criteria	Carried Out by	Date	Audited by
Carry out Monthly Maintenance		Workshop	Replace any damaged or worn or incorrectly functioning parts			
Test brakes using the Brake Test Tool	Minimum torque of 25Nm	Workshop	Replace any damaged or worn or incorrectly functioning parts			
Replace 'Brake Test Next Due' label		Workshop	Record date next due in Maintenance Records			

7.6 Six Monthly Maintenance

Maintenance Task	Instruction	Location	Pass/Fail Criteria	Carried Out by	Date	Audited by
Carry out Three Monthly Maintenance		Workshop	Replace any damaged or worn or incorrectly functioning parts			
Examination	Assemble trolley to inspect tower. Carry out Visual inspection	Workshop	No signs of obvious damage or permanent deformation. No deformation, cracked welds and all parts fit together as intended			

8 TEST SPECIFICATION

The Scaffold Trolley should be tested to the following specification after any structural repairs have been carried out, or when the trolley has been damaged.

Note the testing of the Brakes is defined under the Maintenance section of this User Guide. This is important as the brakes must be checked and maintained before testing.

1. Check the brake lever releases the brakes when operated and the brakes return when removed.
2. Assemble one tier of a scaffold tower onto the Scaffold Trolley and then position onto a level test track. Ensure the brakes are on.
3. Check that there is no deformation by ensuring all wheels are in contact with the rail head to within 2.0mm. Replace the Scaffold Trolley if the deformation exceeds this limit.
4. Lower 1051.5kg UDL test mass onto the tower floor. (1.5 x 701kg) Roll the trolley up and down the test track once.
5. After 1 minute remove the mass and re-measure the heights. There should be no more than 1.5mm difference between the two measurements.
6. Check the Scaffold Trolley frame has no deformation and weld damage. Replace the Scaffold Trolley if the deformation exceeds this limit.
7. Lower a 225kg calibrated test mass onto the tower floor. Connect a calibrated load cell across both Scaffold Trolley frames. Pull the load cell until it reads 20kg, checking that the 2 off braked wheels do not rotate. It is acceptable for a lower mass to be used provided the pull force shown on the load cell is still attained.
8. For non-insulated wheels only, using the resistance meter check the resistance between the trolley frame and the wheels is less than 0.15Ω.
9. For insulated wheels only, using the resistance meter check the resistance between the trolley frames and wheels is greater than 5MΩ.
10. For insulated wheels only, using the resistance meter check the resistance between one wheel and the other opposing wheel (that will sit on the other rail) is greater than 5MΩ. Repeat for the other pair of wheels.

Permaquip Ltd offer a testing and maintenance service – please contact us for further details.

9 TRAINING



Persons that will operate, maintain and test the Scaffold Trolley should undertake a programme of training. This programme of training should include the following aspects:

- Product familiarisation.
- Component location and function.
- Product preparation.
- Safe and Correct Use.
- Maintenance.
- Testing.
- Practical experience.

Permaquip Ltd offer a training service – please contact us for further details.

10 ORDERING

10.1 Main Components and Assemblies

DESCRIPTION		PADS Cat. No.	PART NO
Scaffold Trolley (without Scaffold Tower shown)		PA05/03390	33014
Brake Test Tool			34711

For spare parts please refer to the Scaffold Trolley Spare Parts List.

Our contact details are shown on the front of this User Guide.

In order to avoid delay and to have your orders fulfilled promptly,

Please telephone, e-mail, fax or write giving the following information:

- 1. Company name.**
- 2. Contact details.**
- 3. Invoicing and delivery details.**
- 4. Purchase order number.**
- 5. Method of delivery.**
- 6. Part number, description and quantity for each item.**

Your Notes: